

# HASSELBLAD® 205TCC

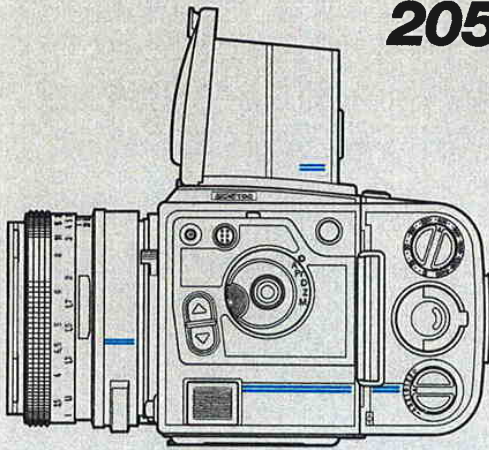

## INSTRUCTION MANUAL

### Hasselblad 205TCC Instruction Manual Contents

3 Hasselblad 205TCC Introduction	21 Selftimer
4 Parts and Components	21 Grip Cushion
6 Getting started	22 Front
6 Battery	22 Shutter Speed Ring
6 Cocking the camera	22 Exposure Release Button
6 Front Protective Cover	22 Cable Release
6 Attaching the Lens	23 Lens Catch & Shutter Speed Ring Lock
7 Removing the Lens	24 Rear Side and Focal Plane Shutter
8 Rear Protective Cover	25 Bottom Side
8 Attaching the Magazine	25 Top Side
9 Removing the Magazine	26 Viewfinder System
9 Magazine Status Indicator	26 Changing Focusing Hood/Viewfinder
9 Winding Crank	26 Changing Magnifier
10 Removing the Winding Crank	27 Changing Focusing Screen
10 Attaching the Winding Crank	28 Left Hand Side
11 Strap and Strap Lugs	28 Mode Selector
11 Attaching the Strap	28 Automatic Exposure Lock (AE-lock)
11 Removing the Strap	29 Adjustment Keys
11 Focusing Hood and Magnifier	29 Flash Connectors
12 Opening the Focusing Hood	29 Display Illumination
12 The Built-in Magnifier	30 Lenses
12 Closing the Focusing Hood	30 FTCC-lenses
13 Viewfinder Image and Display	31 FTCC-lens Functions
13 Focusing Screen	31 Aperture
13 Exposure Meter	32 Focusing and Depth-of-field
13 Viewfinder Display	32 Depth-of-field Preview
14 Control Panel	32 Infra-red (IR) Photography
16 Left Hand Grip	33 Exposure Value (EV)
16 Activating Camera & Metering System	33 Other Hasselblad Lenses
17 Focusing, Exposure, Viewfinder Display	34 TCC Magazine Operation
18 Detail Instructions	34 Loading the Magazine
18 Display Symbols	36 Magazine Load Status
20 Right Hand Side	36 Film Tab Holder
20 Double Exposure	36 Film Speed Dial
20 Mirror and Mechanism Pre-release	37 Film Contrast Dial

37 Film Plane Indicator	82 Camera Care, Service and Guarantee
37 Removing the Film	83 APPENDIX A
38 205TCC Metering System and Operating Modes	83 Hasselblad 205TCC with CF- and C-lenses
38 The Metering System	83 CF-lenses
39 Operating Modes	83 CF-lens Design and Function
39 A Automatic Mode	84 F-setting
40 How to use the "A" Mode	85 How to use the CF-lens
40 Pr Programming Mode	86 Flash photography with CF-lens
44 How to use the "Pr" Mode	87 Lens in F Mode
47 D Differential Mode	87 Dedicated and Non-dedicated Flash Units
47 How to use the "D" Mode	87 Lens in C Mode
47 Z Zone Mode	87 Dedicated Flash Units
50 How to use the "Z" Mode	89 Non-dedicated Flash Units
52 M Manual Mode	90 C-lenses
52 How to use the "M" Mode	90 How to Use the C-lens
54 Warning Functions	91 Flash Photography with C-lens
54 Permanent Warnings	92 APPENDIX B: Spotmeter viewing angles
55 Optional Warnings	93 APPENDIX C: Dedicated Fill-in Flash
56 Flash Photography	
56 Dedicated Flash Units	
57 How to use the Dedicated Flash	
57 Flash set in TTL Mode	
60 Flash set in Automatic Mode	
63 Flash set in Manual Mode	
66 Non-Dedicated Flash Units	
68 How to use a Non-dedicated Flash	
69 205TCC with other Hasselblad Lenses	
69 F-lenses	
70 How to use the 205TCC with an F-lens	
71 Accessories	
71 Accessory Mounts	
72 Major TCC Accessories	
74 Hasselblad System Chart	
76 Trouble-shooting	
79 Technical Specifications	
81 Camera Body Dimensions	

82 Camera Care, Service and Guarantee
83 APPENDIX A
83 Hasselblad 205TCC with CF- and C-lenses
83 CF-lenses
83 CF-lens Design and Function
84 F-setting
85 How to use the CF-lens
86 Flash photography with CF-lens
87 Lens in F Mode
87 Dedicated and Non-dedicated Flash Units
87 Lens in C Mode
87 Dedicated Flash Units
89 Non-dedicated Flash Units
90 C-lenses
90 How to Use the C-lens
91 Flash Photography with C-lens
92 APPENDIX B: Spotmeter viewing angles
93 APPENDIX C: Dedicated Fill-in Flash

**Service and Maintenance**  
The Hasselblad products are exceptionally reliable and durable, but continuous and extensive professional use will require maintenance and overhaul at regular intervals at an authorized Hasselblad Service Center. Turn to page 82 and read about maintenance and service!

**Warranty**  
Provided you purchased the equipment from an authorized Hasselblad dealer or distributor it is covered by an international warranty for one year from the date of delivery. Read more about the warranty on page 82!

### HASSELBLAD 205TCC Tone and Contrast Control

With the Hasselblad 205TCC in your hand you have a tool with a full range of new features. TCC stands for Tone and Contrast Control, a feature that by itself vastly increases your possibilities to control the entire photographic process far beyond what you could do with the previous models. The camera, however, also permits you to use most of the accessories you already have. And it is still you and not the camera that controls your work!  
The meticulously shielded and highly accurate spotmeter provides the metering system with the most precise readings in fast action shots or carefully contemplated artistic creations. For the first time you can select the "zone-mode" and let the processor in the camera adjust the exposure for the planned contrast-compensating development correction. Through the viewfinder display it provides you with information on zones, contrast differences, shutter speeds and aperture settings. And still it is the photographer that controls the image.  
The 205TCC has four different modes of operating the metering system, easily selected with the mode selector dial on the control panel. And in addition it also has a programming mode where you can insert e.g. the dynamic range of the film to obtain a warning signal when your exposure values are off limits. With a TCC film magazine attached the camera processor automatically sets the film sensitivity information set on the magazine, but if you are using an ordinary film magazine that is not adapted for the 205TCC you can insert the film speed data yourself into the memory of the system. You also can set the selftimer delay within wide limits.

Your flash pictures are made easier and more accurate with the 205TCC combined with a dedicated flash unit, such as the Hasselblad Profiflash 4504. The sophisticated metering system in the 205TCC meters the light off the film and controls the flash duration for precise exposures also when the flash is combined with ambient light.

Of course you cannot have all this "for free". It takes a sophisticated and powerful electronic setup to keep track of all this information. The 205TCC is provided with a digital system with active members in lenses and magazines, communicating with the "brain", the central processor, through a data bus. Digital operation and databus communication give an unsurpassed functional reliability.

In spite of all its advanced design the 205TCC is still a part of the Hasselblad System and represents a pacesetter system expansion. With the spotmeter built into the camera body you can change viewfinders and focusing screens and you can also use most of your present accessories, some however with minor limitations in the TCC functions.

You will recognize the TCC system by the double blue lines appearing on the left hand side of the TCC camera body and all the TCC accessories.

Read this Instruction Manual carefully and follow the step-by-step instructions to get the most out of this fabulous camera and to avoid unnecessary mistakes.

205TCC, Parts and Components

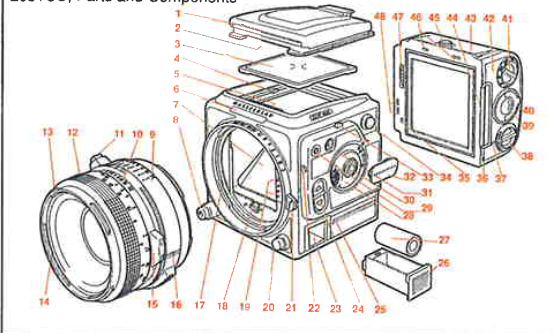

1 Focusing hood cover	18 Drive shaft	33 Display illumination button
2 TCC recess	19 TCC-connection bracket	34 Strap lug
3 Acute-Matte* focusing screen	20 Lens catch and Shutter speed ring lock	35 Indicator trigger slot
4 Focusing screen catch	21 Shutter speed ring	36 Film plane indicator
5 Liquid crystal display (LCD)	22 Selftimer indicator	37 System mark
6 Display illumination window	23 Battery compartment	38 Film contrast dial
7 Viewfinder mirror	24 Adjustment button	39 Film load indicator
8 Shutter release button	25 Grip cushion with System mark	40 Film holder key
10 Depth-of-field scale	26 Battery cassette	41 Film speed dial
11 Interlock button (not on TCC)	27 Battery	42 Film holder
12 Focusing ring	28 Mode selector dial	43 Film magazine
13 Lens front bayonet, exterior	29 PC socket	44 Magazine slide
14 Lens front bayonet, interior	30 Automatic exposure lock, AE-lock	45 Film magazine catch
15 Depth-of-field preview knob	31 Dedicated flash connector	46 Magazine hook slot
16 System mark	32 Flash connector socket cover	47 Magazine gear
17 Lens mount		48 System connectors

\*Acute-Matte designed by MINOLTA

205TCC, Parts and Components

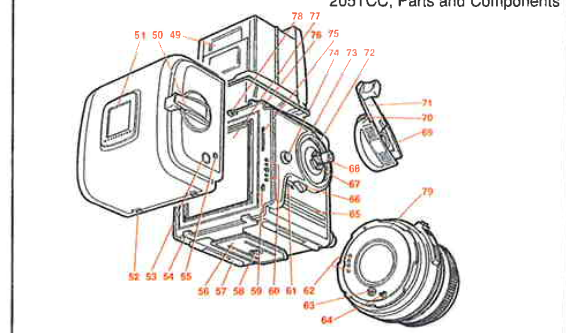

49 Focusing hood	60 TCC connectors	70 Winding crank catch
50 Film winding crank	61 Selftimer indication	71 Winding crank
51 Film tab holder	62 TCC connectors	72 Winder bayonet mount
52 Magazine support slot	63 Lens drive shaft	73 Winding crank index
53 Frame counter	64 Lens drive shaft catch	74 Strap lug
54 Magazine support	65 Grip cushion	75 Magazine driving gear
55 Magazine status indicator	66 Mirror release/selftimer button	76 Magnifier
56 Quick coupling side	67 Selftimer	77 Shutter curtain
57 Camera support	68 Double exposure button	78 Magazine hooks
58 Tripod thread 1/4"	69 Crank hub	79 Lens bayonet plate

**NOTE:** In the text the positions of components are described in relation to the camera as you see it when taking a photograph, i.e. the lens is on the front, the viewfinder is on the top, the winding crank is on the right hand side, and the control panel is on the left hand side.

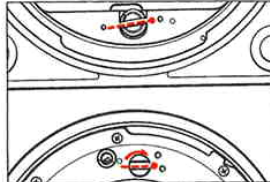
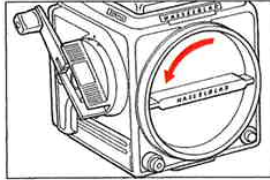
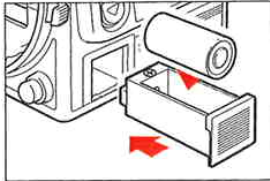

6 Getting started

### Getting Started

This section describes how you prepare your Hasselblad 205TCC for use. You will find comprehensive information how to operate the camera in the section starting on page 18. Follow the instructions step by step to avoid jamming or damaging the camera. Always keep the rear protective cover on to protect the shutter curtain when the magazine is detached!

#### Battery

The battery compartment and cassette is located in the lower forward corner on the left hand side of the camera body. Pull out the cassette and install the battery - 6V type PX28 (UCAR 537) - according to the marking on the cassette. Push the cassette all the way back into the compartment.

#### Cocking the Camera

Cock the camera after installing the battery. Fold out the winding crank on the right hand side, press the button in the center of the crank and rotate it clockwise one turn until it locks (Cf. page 20, Double exposure).

#### Front Protective Cover

The front protective cover is attached to a bayonet mount. Rotate it as indicated by the arrow in the illustration and lift it out of the mount.

#### Attaching the Lens

Remove the lens' rear protective cover by rotating it clockwise and lifting it off the lens.

Check that both the camera and the lens are cocked. The lower illustration on page 6 shows the proper position of the drive shaft against the index marks for the camera drive shaft (top) and the lens drive shaft (bottom). You will find that holding the camera body in your left hand and the lens in your right hand as shown in the illustration is the easiest way to attach the lens.

When you have aligned the red index on the lens with that on the camera body as shown in the illustration, the lens will fit easily into the bayonet mount. You can then rotate it clockwise until it stops with a faint click as the lens locks in place.

#### Removing the Lens

Depress the lens catch button, rotate the lens counter-clockwise and lift it out of the bayonet mount.

**NOTE:** You can only attach and remove the lens when the camera is cocked (fully wound) and not in pre-released mode (see page 20).

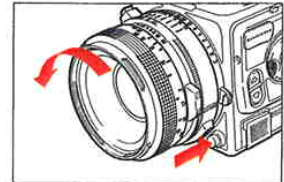
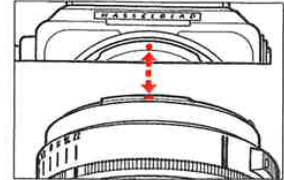
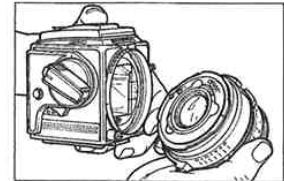

Getting started 7

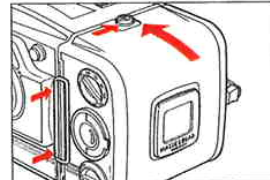
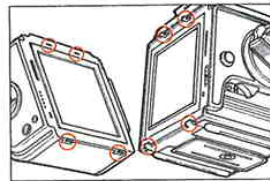

8 Getting started

#### Rear Protective Cover

Depress the catch, tilt the cover backwards and lift it off. Always keep the rear protective cover on to protect the shutter curtain when the magazine is detached!

#### Attaching the Magazine

Ensure that the magazine slide is fully inserted and that the magazine status indicator is white. If the indicator is red, then follow the instructions on page 9. Rest the magazine on the magazine supports with the support lugs properly engaging the recesses in the magazine bottom. Carefully swing the magazine towards the camera body, checking that the magazine hooks fit into the slots in the magazine. Push the magazine gently but firmly against the hooks while sliding the magazine catch to the right.

Release the button when the magazine makes contact with the camera body and then push the button to the left to ensure that it has reached the locked position. Remove the slide to positively lock the magazine to the camera body.

#### Removing the Magazine

It is advisable to have the camera fully wound and the magazine status indicator showing white. If the indicator shows red, then follow the instructions below. Insert the magazine slide fully and with the hinge towards the front of the camera. Slide the magazine catch to the right, tilt the magazine back and lift it off the supports.

**NOTE:** The magazine cannot be removed without inserting the magazine slide. The slide protects the film from fogging. Note also that the camera cannot be operated when a magazine with the slide inserted is attached to the camera.

#### The Magazine Status Indicator

The status indicator on the right hand side of the magazine shows whether the magazine is ready to operate (white) or not, i.e. the film has not been advanced (red). Do not attach a magazine showing white to a camera that is not recocked! Wind it first, otherwise you will lose one frame. Do not attach a magazine showing red to a fully wound camera! That could result in an unintentional double exposure since the frame in position in the magazine is probably already exposed. If the status indicator shows red, release the camera (page 17) before attaching the magazine. Then, when you wind the camera, the film will be advanced one frame.

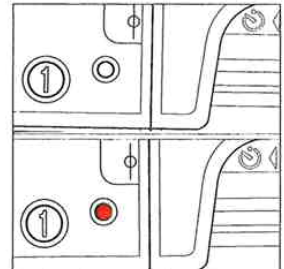

Getting started 9

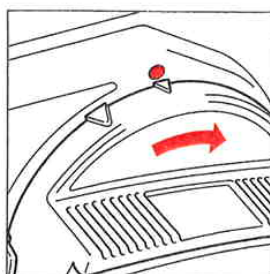
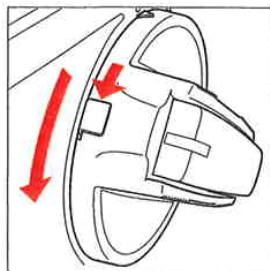

10 Getting started

#### The Winding Crank

One full revolution of the winding crank winds the camera and lens mechanisms and transports the film to the next frame. Underneath the crank are the drive shaft and the bayonet mount for the Hasselblad Winder (pages 73, 74), which can be attached after removing the crank. It is recommended that the camera is fully wound when the crank is removed or replaced.

#### Removing the Winding Crank

To remove the crank push the catch lever on the rear of the crank hub downwards while rotating the crank counter-clockwise. Then pull it straight out from the shaft.

#### Attaching the Winding Crank

On the side of the crank hub are two triangular index marks, a larger one and a smaller one. Attach the crank to the shaft with the smaller mark aligned with the red dot located immediately above the mount. While pushing the crank against the camera body rotate it clockwise until the larger mark is aligned with the red dot.

#### Strap and Strap Lugs

The 205TCC is delivered with a medium wide shoulder strap, packed separately. You will find other types of straps in the Hasselblad Product Catalog. All straps are provided with special clips for easy attaching and removing of the strap.

#### Attaching the Strap

Place the main body of the strap clip over the strap lug on the camera (see figure). Press the tip of the clip towards the camera while pulling the strap to slide the clip over the lug to the locked position.

#### Removing the strap

Lift the locking plate of the clip high enough to pass over the top of the lug. Push the clip in the direction opposite to the strap to slide it off the lug.

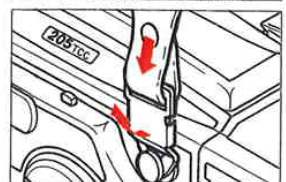
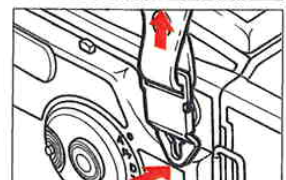
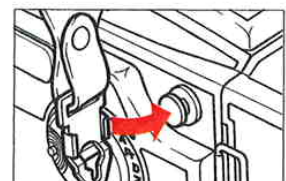

Getting started 11

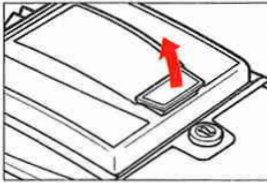

### Focusing Hood and Magnifier

#### Opening the Focusing Hood

Lift the lid with a firm grip on the tab at its rear edge and swing it up to a vertical position. The hood unfolds automatically and locks in open position.

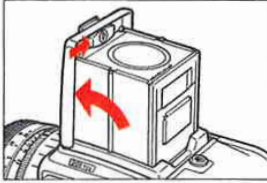

#### The Built-in Magnifier

Use the built-in 4x magnifier to enlarge the viewfinder image, e.g. for more accurate focusing. To unfold it, push the oval catch inside the lid to the right, as indicated in the illustration.

To fold the magnifier down, simply push it back towards the lid until it locks.

The magnifier can easily be exchanged for one with a suitable correction lens to match your individual eyesight (see page 26).



#### Closing the Focusing Hood

"Pinch" the side plates at the hinge points and fold the hood back down.

12 Getting started

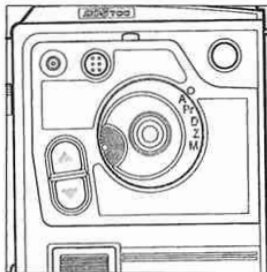

### The Control Panel

The control panel occupies most of the left hand side of the camera body. It includes all the controls for the various functions of the 205TCC, such as:

- The Flash Connectors
- The Display Illumination Switch
- The Mode Selector Dial
- The Adjustment Buttons

#### Flash Connectors

The flash connectors are located underneath the protective cover in the upper forward corner of the control panel. The smaller one is a standard PC-socket and the larger one is a 6-pin connector for dedicated flash units.

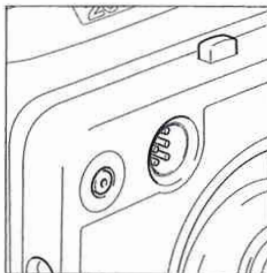

#### The PC-socket

Non-dedicated flash units and certain adapters should be connected to this socket.

#### The Dedicated Flash Connector

A dedicated flash unit connected to this 6-pin outlet directly or through a suitable adapter will be fully controlled by the camera processor.

You find detailed information on flash photography on pages 56-68.

#### The Display Illumination

Pressing the button above the flash connectors turns the display illumination on or off. The switch has a toggle function.

14 Getting started

### Left Hand Grip

Holding the 205TCC in your left hand with your index finger on the release button, as shown in the upper illustration below, is the most convenient grip. You can reach the AE-lock and the adjustment keys with your left thumb (lower illustration below) and your right hand is free for focusing, aperture setting, operating the crank or for the changing of lens or magazine.

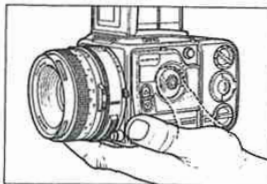
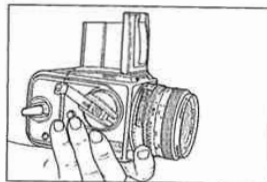

16 Getting started

### Activating the camera and the metering system

Before you operate the 205TCC you have to cock the shutter (if it is released) and switch on the metering system. To be able to release it you also have to remove the magazine slide.

The fully wound 205TCC can be started in two different ways:

1. By depressing the exposure button half-way in, i.e. to the "pressure point".
2. By depressing the AE-lock button.

Activation as per 1. above can only be performed when the magazine slide is removed.

Activation as per 2. is not possible if the AE-lock has been kept depressed for more than 16 seconds.

Keep the magazine slide inserted when you wish to avoid increased battery power consumption caused by unintentional activation of the metering system.

The electronic system and the viewfinder display turn off automatically 16 seconds after the last key or button operation, but all relevant data are stored in the memory.

### Viewfinder Image and Display

#### Focusing Screen

The Hasselblad 205TCC is equipped with the Acute-Matte\* focusing screen featuring the highest brightness and resolution among the Hasselblad focusing screens. The center of the screen is indicated by a hairline cross and a circle of dots indicating the metering area covered by the built-in spotmeter. The circle has a 6 mm diameter. See page 27 how to change the focusing screen.

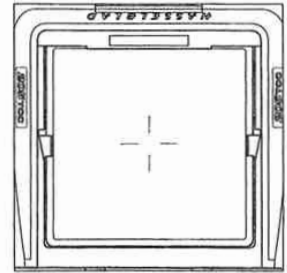

#### The Exposure Meter

The exposure meter is a spotmeter, meticulously shielded to avoid all influence of stray light. The metering area corresponds to an image angle from 1° to 7° depending on the lens used. The metering range for a film speed of ISO 100/21° extends from EV -1 to EV 20, corresponding to 8s at f/2 to 1/2000s at f/22.

#### The Display

Located above the upper edge of the viewfinder image is the display, which is the information center of the camera. You find a comprehensive description of the display and its symbols on pages 18-19.



\*Acute-Matte designed by MINOLTA

Getting started 13

### The Mode Selector Dial

With the mode selector dial you can select any of the five operating modes **A**, **Pr**, **D**, **Z** or **M** available in the 205TCC. **A**, **D**, **Z** and **M** are used for photography and **Pr** for programming of certain functions.

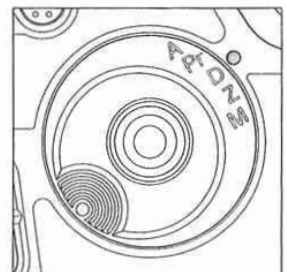

#### The Automatic Exposure (AE) Lock

In the center of the mode selector dial is a push-button, marked with a red circle. It operates the AE-lock and some other functions, depending on the setting of the mode selector dial. You can also use it to start the electronic operating system in the camera.

#### The Adjustment Buttons

These keys also have multiple functions depending on the setting of the mode selector dial.

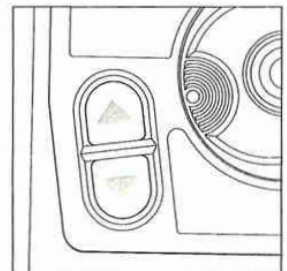

All the functions of the mode selector dial, the AE-lock and the adjustment buttons are described in detail on the pages 28-29.

Getting started 15

### Focusing, Exposure Release and Viewfinder Display

Turn the focusing ring (page 31) until the image of the subject appears sharp in the viewfinder. Depress the exposure button to the pressure point.

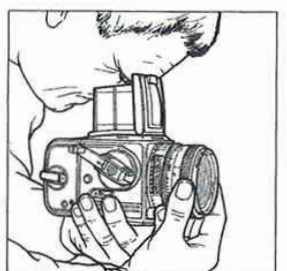

If the mode selector dial is set in **A**, **D** or **Z** position the display now shows – besides a few other symbols described in the following section of this manual – the preselected aperture and the shutter speed calculated by the camera. With the mode selector set at **M** the display shows the letter **M**, the pre-selected aperture and shutter speed set on the shutter speed ring.

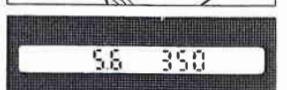

You can now press the release button all the way to make the exposure. After releasing the button you can rotate the winding crank one full turn until it locks to rewind the camera and advance the film one frame.

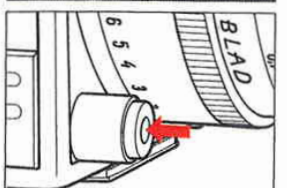

Getting started 17

**Operating details**



**Viewfinder Display & Symbols**

The display is shown in the illustrations the way it is built into the camera body. When you use a prism viewfinder the display appears reversed, but the microprocessor adjusts all the indications to make them fully readable.



**Flash Ready Signal**

The flash symbol is illuminated green when a dedicated flash is connected, turned on and ready to be fired (pages 56, 88).



**Manual Mode**

The mode selector dial is set at **M** (page 52).



**Selftimer Function**

Flashes when the selftimer is activated. Appears also by programming the length of the selftimer delay in **Pr** mode (page 43).



**Differential Mode**

The mode selector dial is set at **D** (page 47).



**Plus/Minus Sign**

Appears together with a correction or deviation value when the mode selector dial is set at **A**, **D** or **M**.



**Zone Mode**

The mode selector dial is set at **Z** (page 49).



**Figures**

Eight 7-segment figures indicate corrections, deviations, zones, EV, shutter speed and aperture in operation modes **A**, **D**, **Z** and **M** as well as programming functions in **Pr** mode and certain warnings in various modes of operation.



**Fraction Indication**

One, two or three dashes to the right of the figure indicate 1/4, 1/2 and 3/4 step higher value than indicated by the figure.



**Film Speed**

Indicates film speed set on TCC-magazine dial or inserted manually in **Pr** mode (pages 43, 45). **S** in ISO is also used to indicate seconds at very slow shutter speeds (0,7s to 16s).



**Battery Check**

Appears when battery capacity is low (page 54).



**Magazine Check**

Indicates that the magazine on the camera is not TCC-adapted.



**Automatic Mode**

Indicates that the mode selector dial is set at **A** (page 39).



**Warning Symbol**

Flashes red together with one or more of the other symbols to indicate various problems (page 54).

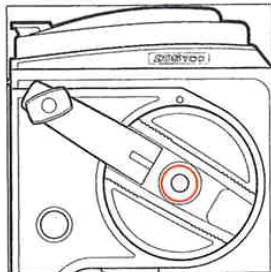

**The Right Hand Side**

On the right hand side of the camera body are the winding crank, described on page 9, and the pre-release and selftimer lever.

**Double Exposure**

You can make double (or multiple) exposures by rewinding the camera without advancing the film. This is possible by depressing the double exposure button in the center of the crank hub and simultaneously turning the crank slightly clock-wise. Then you can release the button and complete the winding until the crank locks.

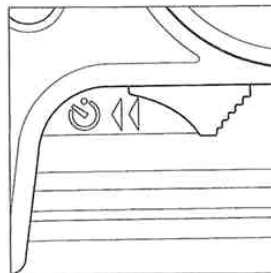

**Mirror and Mechanism Pre-release**

By pre-releasing certain camera functions and lifting up the mirror you can avoid camera vibrations, reduce the sound level and shorten the time delay. This is done by pressing the pre-release lever **once**. To reset the mechanism and lower the mirror again you simply perform the operation for a double exposure as described above. Since the mirror is lifted the light metering is interrupted and locked on the latest recorded value.

20 The Right Hand Side

**The Selftimer**

Pressing the pre-release lever a **second** time starts the selftimer function. This is indicated by the selftimer symbol in the viewfinder display and by a flashing red light on the camera body to the left of the lens mount.

The standard delay in the selftimer is 10 s but it can be set in intervals between 2 s and 60 s in the **Pr** mode (pages 43, 45). At the beginning the light flashes twice per second, but when two seconds remain of the delay time it increases to four times per second and changes to a continuous light the last half second. You can interrupt the selftimer function at any time by pressing the pre-release lever again or by a "blind" rewind as for double exposure.

The selftimer function is inoperative when the shutter speed ring is set in positions **B** or **C** (pages 22, 23).

**The Grip Cushion**

A rubber cushion along the lower edge of the right hand side provides a safe and comfortable grip.

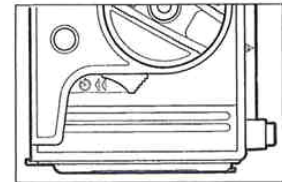
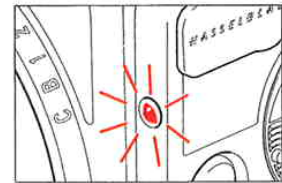
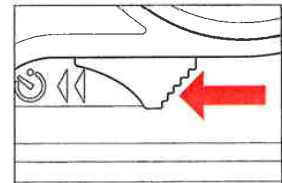

The Right Hand Side 21

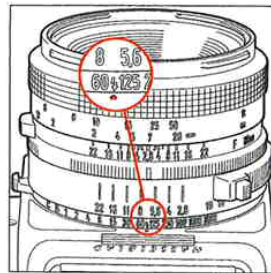

**The Front**

**The Shutter Speed Ring**

The shutter speed ring for the focal plane shutter in the 205TCC has speed markings from 1 s to 1/2000 s as well as **B** and **C**. Between the markings are intermediate half speed click stop settings. One of these settings - 1/90 s, marked with a flash symbol - is the fastest shutter speed for flash synchronisation with the focal plane shutter (pages 56, 86). In all modes of operation except **M** the microprocessor automatically calculates and sets the shutter speed within the range 16 s to 1/2000 s, irrespective of the ring setting. If you require a shutter speed slower than 16 s (or 1 s in **M** mode) you have to set the speed ring at **B** (page 23) and measure the exposure time yourself. The setting marked **C** is used together with **CF** and **C** lenses only. **NOTE:** When the mode selector dial is set at **M** (page 52) the display indicates the accurate shutter speed for the intermediate settings.

**Exposure Release Button**

In the lower right hand corner of the front, within comfortable reach of the left hand grip, is the exposure release button. The button has three different functions:

- A. When depressed to the "pressure point":
  1. Activating the camera.
  2. Changing the display to indicate aperture and shutter speed.

22 The Front

- B. When depressed all the way in:
3. Release to make the exposure with set or calculated values.

The exposure button is locked when the magazine slide is in the magazine.

**Cable Release**

When using shutter speeds slower than 1/30 s you are recommended to put the camera on a tripod and use a cable release, attached to the threaded mount in the center of the exposure release button. The cable release and the exposure button have identical functions.

**Lens Catch & Shutter Speed Ring Lock**

In the lower left hand corner of the front is the lens catch button. To remove the lens you have to keep the button depressed while rotating the lens clockwise as seen from behind. The button also operates the lock for the shutter speed ring settings **B** and **C**. You have to keep it depressed when moving the ring to either of these settings.

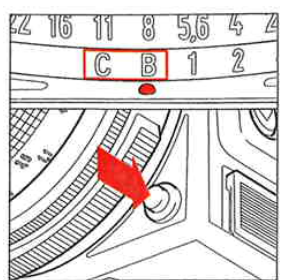
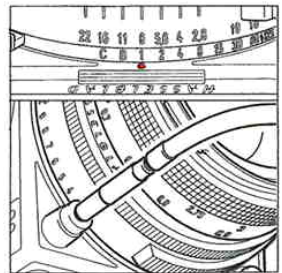

The Front 23

### The Rear of the Camera and the Focal Plane Shutter

Avoid leaving the rear of the camera and the shutter curtains unprotected! Always attach the rear protective cover when the magazine is removed!

The opening in the rear of the camera is normally covered by the shutter curtain. The 205TCC has a mechanically powered but electronically controlled focal plane shutter with two textile curtains running from left to right across the opening. The running time for the curtains is 1/90 s. In all modes except Manual Mode (pages 39-53) the shutter speeds are calculated by the metering system which controls the shutter. The shutter speeds are adjusted with 1/12 EV-

step increments but for practical reasons only shutter speeds for 1/2 EV-steps are indicated in the viewfinder display.

**Caution:** Whether the shutter is cocked or released, one shutter curtain is always exposed in the opening. When the rear of the camera is not covered by a magazine or a protective cover care should be taken when handling the camera. The curtain is sensitive to damage. Refrain from touching the curtains!

To the right of the opening are the magazine driving gear and the magazine status indicator trigger (page 9). There are also the contact pins for the data bus connection between the magazine and the central processor in the camera body. The contact pins are sensitive to contamination and should not be touched.

At the bottom edge of the back are the magazine supports and close to the top are the magazine hooks – both together serving to lock the magazine on the camera body (page 8).

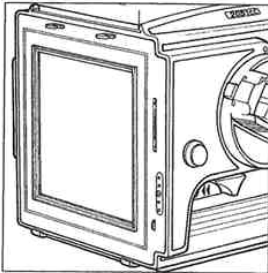

24 The Rear & The Shutter

### The Bottom

At the bottom of the camera are the quick coupling plate, the tripod thread and two ridges, supporting the camera when placed on a flat surface. The quick coupling plate fits the Hasselblad accessories, such as the tripod quick coupling and the flash bracket. The tripod thread is 1/4" and fits also to the retaining screws of the flash rail and the flash bracket.

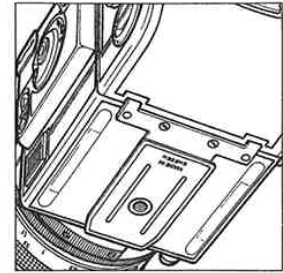

### The Top

The entire top of the camera is covered by the viewing components (page 28). The camera body is supplied with the collapsible focusing hood, which also serves as a protective cover for the focusing screen. In front of the HASSELBLAD sign there is a window for the daylight illumination of the viewfinder display screen.

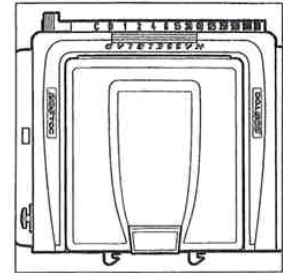

The Bottom & The Top 25

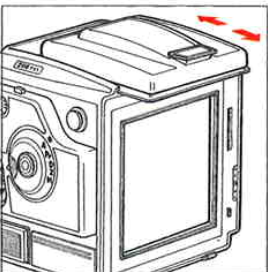

### The Viewfinder System

#### Changing the Focusing Hood or Viewfinder

To remove the focusing hood for using any other viewfinder within the TCC system detach the magazine (or the protective cover). Also fold down the focusing hood to protect it from being damaged.

Remove the hood by sliding it to the rear in its guide slots. Slide the replacement viewfinder into the slots and push it forward until it stops. When fully inserted the viewfinder is retained in position by a spring-loaded ball latch until you have reattached the magazine or the protective cover.

#### Changing the Magnifier

The standard magnifier lens plate can be changed for a plate with a correction lens to compensate for individual eyesight. The standard magnifier marked -1 provides a comfortable viewing of the focusing screen and the display for most users. Correction lenses are available with powers ranging from +3 to -4 diopters.

Change the magnifier as follows:

1. Remove the focusing hood from the camera body and open it by lifting the lid.
2. Release the magnifier by pushing the catch to the left. Push the magnifier halfway down and pull out the lens plate.
3. Keep the plate holder halfway down and insert the replacement lens plate with the printed side up. Fold the hood and put it back on the camera.

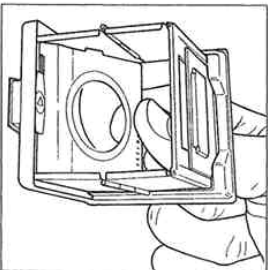

26 The Viewfinder System

### Changing the Focusing Screen

Your 205TCC is equipped with the exceptionally bright and sharp Acute-Matte focusing screen. The center area inside the dotted circle indicates the area metered by the built-in spotmeter (page 38).

If you wish to replace the focusing screen with any of the other focusing screens in the Hasselblad System simply follow the procedure below:

1. Detach the magazine and the viewfinder.
2. Push the two screen latches to the side into their recesses.
3. Place your hand over the screen and invert the camera. The screen will now drop into your hand.
4. Insert the replacement screen with the smooth side up and the sharp-edged corners down. Ensure that all four corners of the screen are positively seated on their supports. You need not return the screen latches. This is done automatically when the viewfinder is replaced.

**NOTE:** Should the screen refuse to drop out by itself ensure that the camera is fully wound, remove the lens and check that the mirror is in the down position. Put a finger through the lens mount and push gently at the screen from underneath, preferably with a soft cloth between the finger and the screen.

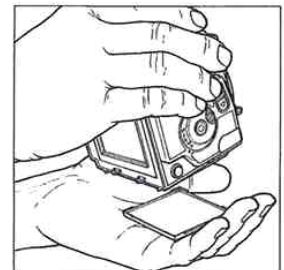
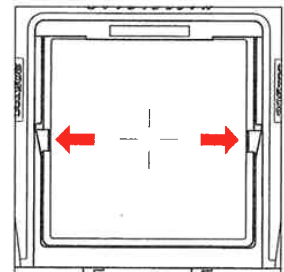

The Viewfinder System 27

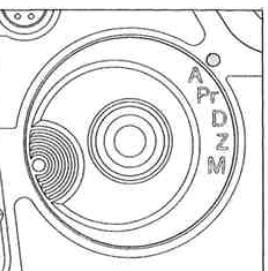

### The Left Hand Side

#### The Mode Selector Dial

The mode selector dial is in the center of the control panel at the left hand side. To select any of the operating modes of the 205TCC simply turn the dial until the symbol for that particular mode is aligned with the red index mark. The different operating modes are:

- A:** Automatic Mode
- Pr:** Programming Mode
- D:** Differential Mode
- Z:** Zone Mode
- M:** Manual Mode

The functions of these modes are described in detail on pages 38-53.

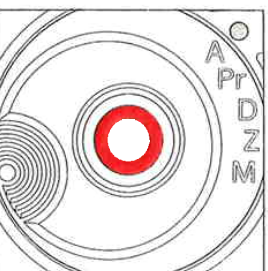

28 The Left Hand Side

### The Adjustment Buttons

Similar to the AE-lock the adjustment buttons also have different functions depending on the selected mode. A single push on the upper button increases and on the lower button decreases the value to be adjusted. If you keep the button depressed for more than 0.7s the value starts to change at a rate of three steps per second until the button is released.

### The Flash Connectors

The larger six-pin TTL-connector provides automatic control of dedicated flash units. The Hasselblad Prolash 4504 can be connected directly to the 205TCC but other dedicated flash units may require a suitable adapter, such as the Hasselblad SCA-adapter 390 or 590, between the unit and the camera. The smaller connector is a common PC-socket for any kind of flash unit. You can find further instructions on flash photography with the 205TCC on pages 56 and 86.

### Display Illumination

In low light levels depressing the switch button on the upper edge of the control panel switches on the illumination of the viewfinder display. The button has a toggle function.

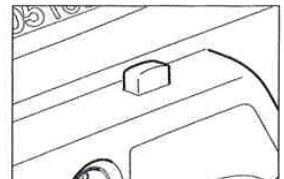
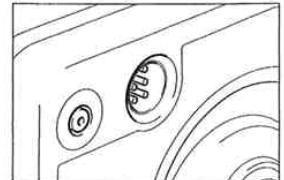
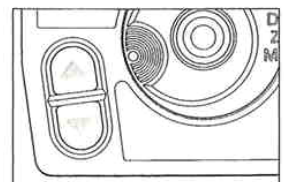

The Left Hand Side 29

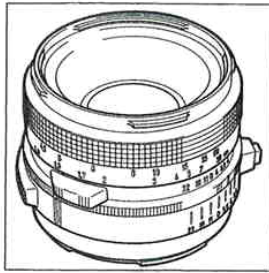

### Lenses

The Hasselblad lenses made since 1957 can be separated in two major groups, each with two sub-groups:

- Lenses with a built-in leaf shutter:
  - C lenses
  - CF lenses
- Lenses without shutter:
  - F lenses
  - F/TCC lenses

All these lenses can be used on the 205TCC, but only the F/TCC lenses will give you access to the full range of exclusive and sophisticated features of the 205TCC.

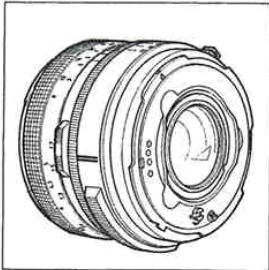

### F/TCC Lenses

The Hasselblad F/TCC lenses which have no built-in shutter can easily be identified by their system sign: the blue twin lines on the left hand side of the aperture ring. Another sign, visible only when the lens is detached from the camera body, are the four databus contact pins in the bayonet plate at the rear of the lens. They are used for the data transmission between the lens electronics and the electronic system in the camera body. The contact surfaces of these pins are sensitive to contamination and should not be touched with your fingers. Attach the protective cover after removing the lens from the camera and never set the lens down on the unprotected bayonet plate!

30 Lenses, F/TCC Lenses

### F/TCC Lens Functions

#### Setting the Aperture

The aperture ring is the closest one to the shutter speed ring on the camera body. Use it to pre-set the selected f-stop. The full f-stops marked on the ring have click stops, but there are also click stops for each intermediate half f-stop. The set aperture value can be read against the heavy index line on the grooved ring in front of the aperture ring. It will also show on the viewfinder display when you depress the exposure button halfway in, i.e. to the pressure point.

The aperture ring has two grooved grips for handling convenience. One of these grips has a push-button which has no function on the 205TCC.

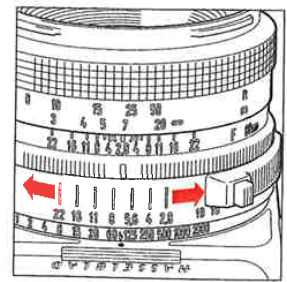

#### Focusing and Depth-of-field

The focusing ring is the rotating ring with a knurled rubber grip closest to the front of the lens. It has two scales for the focusing distance - the white meter scale and the orange inch/foot scale. Rotate the focusing ring until the image of your subject appears absolutely sharp on the focusing screen.

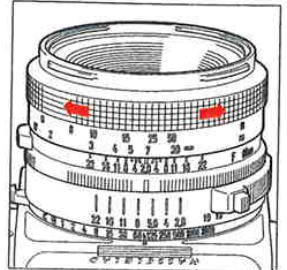

Lenses, F/TCC Lenses 31

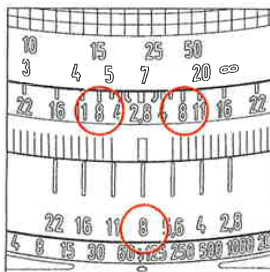

The depth-of-field scale repeats the aperture values on both sides of the heavier index line between ring with the index line and the focusing ring. When the image is focused on the screen you can read the focusing distance opposite the index line in the depth-of-field scale. The depth-of-field limits can be read opposite the left and right values corresponding to the pre-set aperture value. The illustration depicts the depth-of-field for the pre-set aperture value of 8.

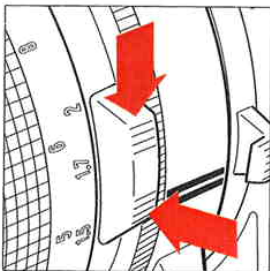

#### Depth-of-field Preview

The lens is normally set at the largest aperture to provide the brightest possible viewfinder image with the shallowest depth-of-field. You can stop down the lens diaphragm to the pre-set aperture by pushing down the depth-of-field preview knob until it locks. To re-open it depress the lower end of the knob.

32 Lenses, F/TCC Lenses

### Infrared (IR) Photography

Infrared light with wavelengths beyond 800 nm are refracted by the lens to an image plane further away from the lens than the image plane for visible light. When photographing with IR light you have to compensate for this difference by setting the focusing distance at the red IR index to the right of the common index line.

Follow this procedure:

- Focus as usual on the focusing screen.
- Mark or memorize the distance on the focusing scale opposite the common index line.
- Rotate the focusing ring to set this distance opposite the IR index.

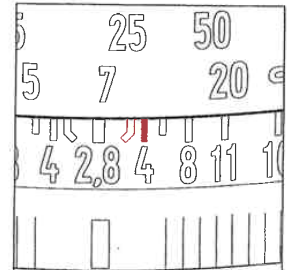

### Exposure Value (EV)

The orange scale on the right hand side indicates the exposure value for the set aperture/shutter speed combination. You read the value opposite the orange triangular index on the shutter speed ring. The scale has no particular function on 205TCC. Do not confuse the exposure value with the light value stored in the metering system when you depress and release the AE-lock (page 28).

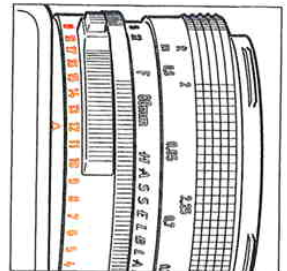

### Other Hasselblad Lenses

How to use other Hasselblad lenses on your 205TCC is described on pages 69-70 and in Appendix A.

Lenses, F/TCC Lenses 33

### Magazine Operation

#### Loading the Magazine

You can load the magazine with film on or off the camera. Off the camera you have to ensure that the magazine slide is inserted with its flat side towards the rear.

Follow the procedure below to load a film:

- cw**=clockwise; **ccw**=counter-clockwise
1. Fold out the film holder key.
2. Turn the key **ccw** and withdraw the film holder.
3. Place an empty take-up spool under the grooved knob of the spool clamp bar. Insert a roll of film under the other end of the bar, turned as in the picture. Remove all of the paper band surrounding the roll!
4. Turn the film holder key **cw** to open the film clamp. Pull 8-10 cm (3-4 in.) of paper backing off the film roll. Slide the side edge under the clamp.
5. Insert the tongue of the backing paper into the slot in the take-up spool.
6. Turn the grooved knob **cw** to align the arrow on the paper with the triangular index on the bar, but no further.
7. Turn the film holder key **ccw**. Insert the film holder into the magazine. Ensure that it is correctly positioned. Turn the film holder key **cw** to lock the film holder in the magazine.
8. Fold out the film winding crank. Rotate it **ccw** about ten turns until it stops. Turn it **ccw** and fold it in.

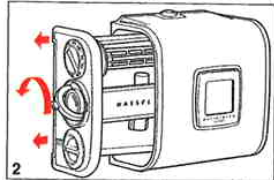
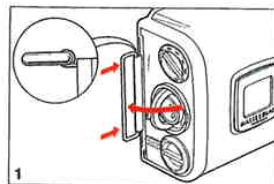

Number 1 will now be displayed in the frame counter window indicating that the loaded magazine is ready for use. The film winding crank is blocked at frame 1 only. It can be used to wind up a partially exposed film at any frame after that. The frame counter is automatically reset when the film holder is withdrawn from the magazine.

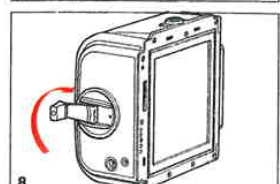
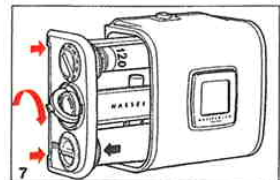
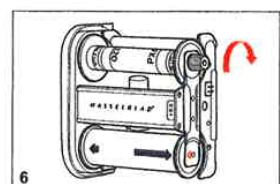
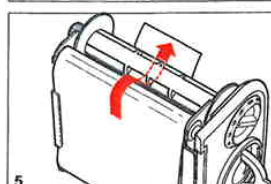
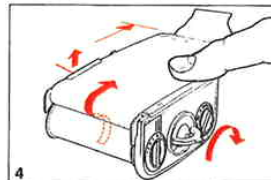
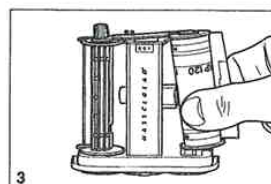

34 Magazine Operation

Magazine Operation 35

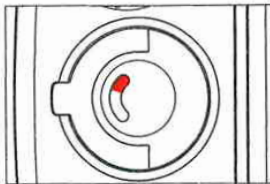

**Magazine Load Status**  
In the center of the film holder key there is a crescent-shaped indicator window that shows white when the magazine is freshly loaded. It gradually changes to red as the film is wound through. An all red indicator shows that the film is used up or that the magazine is empty.

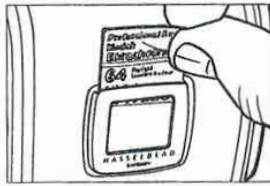

**Film Tab Holder**  
The end tab of the film pack can be inserted in the holder on the back of the magazine as a reminder of the kind of film that has been loaded into the magazine.

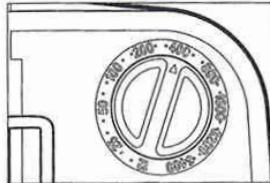

**Film Speed Dial**  
On the left hand side of the magazine above and below the film holder key are two dials. The upper one is the film speed dial. The speed set on this dial is automatically transferred to the metering system in the camera body and displayed in the viewfinder in the Pr mode (page 43). The range of the film speed dial extends from ISO 12 to ISO 6400 with 1/3 and 2/3 intermediate settings.

### 205TCC Metering System and Operating Modes

Pages 28 and 29 described in short how you can select the various operating modes of the 205TCC. The description included, also in short, the function of the different controls on the control panel and how to use them. The following section describes in detail the metering system and the different operating modes.

#### The Metering System

The different methods to start the camera and activate the metering system are described on page 16. The system turns off automatically 16 seconds after the last button operation.

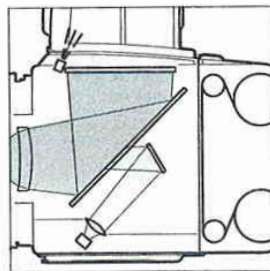

The spotmeter is the most important feature in the metering system. The metering spot is indicated by a circle of dots in the center of the focusing screen. The circle has a diameter of 6 mm which is approximately 1% of the total image area. The corresponding angle of view depends on the focal length of the lens you are using. With the Planar F 80mm it is roughly 4°; with Distagon F 50mm just below 7° and with Tele-Tessar F 350mm as small as 1°. See the chart on page 92 for the accurate metering angles for all focal lengths.

The spotmeter is very sensitive and accurate. It measures the light reflected from the subject within the metering spot and nothing else. Due to its highly efficient shielding it does not react upon light outside the spot. Thus even minor displacements of the metering spot may give unexpected changes in exposure values.

**NOTE:** Like every other reflection exposure meter the spotmeter is adjusted to give an exposure value that in the end produces an 18% grey tone no matter if the metered subject is black, grey, white or any color. If the metered area is brighter or darker than this 18% grey the metering result has to be adjusted manually up or down to obtain the picture result.

The value that is stored in the metering system is the **light value**. This means that the shutter speed calculated by the system is adjusted automatically if the pre-set

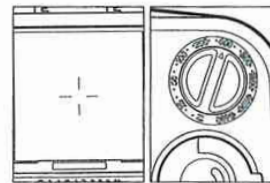

#### How to Use the "A" Mode

The spotmeter in the 205TCC is very sensitive and reacts to the smallest change in the light level within the metering spot (pages 13 and 38). The very efficient shield makes it insensitive to light outside the spot. The spot must be located in the proper subject area and the changing readings in the viewfinder display carefully observed before storing the values or releasing the exposure.

#### Suggested procedure:

1. Pre-set the film speed. With a TCC-magazine set the film speed dial (page 36). With a standard magazine use the Pr mode to enter and store the film speed (page 45).
2. Pre-set the desired aperture.
3. Set the Mode Selector Dial at A and aim the camera to locate the metering spot in a selected subject area.
4. Start the metering system by depressing the exposure release button (page 22) to the "pressure point". The display shows the pre-set aperture and the shutter speed (calculated from that aperture, pre-set ISO value and metered light level), continuously changing the speed as the metering spot is moved to brighter or darker subject areas, and an "A" for Automatic Mode. When you release the button the display shows 0 instead of the aperture number to indicate that the calculated shutter speed keeps the exposure at a "normal" level. If the display goes out the system is re-activated by depressing the exposure button halfway again.

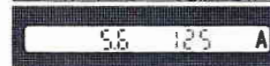

#### Film Contrast Dial

The dial below the film holder key is the film contrast dial which can be used in the zone mode only (Z, page 49). The dial has eight settings from -4 through 0 to +3 corresponding to the contrast control development N-4 through N+3. It informs the metering system how you are going to develop the film in the magazine when you intend to control the contrast by increased or reduced development.

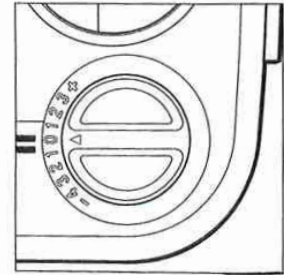

#### Film Plane Index

In front of the film contrast dial, close to the magazine front and moulded into the rubber grip cushion is the film plane index. It can be used to measure the subject-to-film distance in close-up photography.

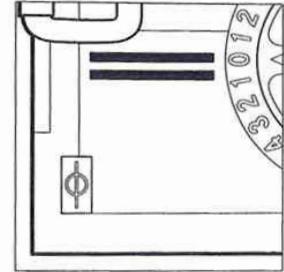

#### Removing the Film

After the last frame has been exposed and the film advanced, the magazine blocks the camera against further release. To remove the exposed film fold out the film winding crank and rotate it clockwise until you can feel that the film is leaving the supply spool. Withdraw the film holder from the magazine and remove the film.

aperture or film speed are changed. The working shutter speed is adjusted in 1/12 EV-steps, i.e. much more accurate than the half speed steps that for practical reasons are used on the viewfinder display.

Other concepts used in this manual are **continuous metering** and **continuous indication**. This means that the system continuously meters the light from the part of the subject which at that very moment is covered by the metering spot and also continuously updates the value displayed in the viewfinder.

Flashing numbers or symbols in the viewfinder indicate that a warning function has been triggered. See pages 54 and 55 about warnings!

**NOTE:** Pre-releasing the camera (page 20) in any of the operating modes always locks the light value that is present at the moment of lifting the mirror.

In the illustrations changing indications are noted with grey symbols and flashing indications by rays around the symbol

#### Operating Modes

The different operating modes are described in the order they appear on the Mode Selector Dial.

##### A Automatic Mode

**Function:** Automatic exposure with aperture priority, pre-selected film speed and calculated shutter speed.

**Features:** Continuous metering of the light value. Locking and storing of the light value at a selected moment for the next single exposure only. Adjustment of the continuous or stored light value  $\pm 5$  EV-steps in 1/4 step increments.

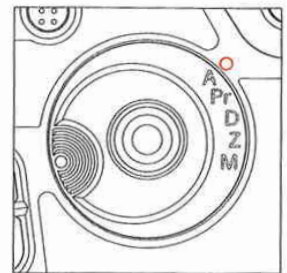

Depressing the exposure button fully at this stage releases an exposure based on the subject area where the metering spot was located at that very moment.

**NOTE:** The system can also be started by depressing the AE-lock button. It then shows the same display as when the exposure button has been released. Depressing the AE-lock button erases all previously stored exposure information.

5. Depress and release the AE-lock button to lock and store the exposure of a selected subject area. The display shows the stored shutter speed and 0 for "no adjustment". If the aperture or ISO setting is changed the shutter speed adjusts automatically.

**NOTE:** Depressing and releasing the exposure button as in p.4 above unlocks the metering system and starts continuous metering.

6. Use the adjustment buttons (page 29) to adjust the stored exposure if necessary. The display shows the + or - amount of adjustment in 1/4 EV-step increments (page 19). The adjusted shutter speed is shown with 1/2 speed-step increments although the shutter speed is actually adjusted in 1/4 steps.

**NOTE:** "+" adjustment decreases and "-" adjustment increases the shutter speed.

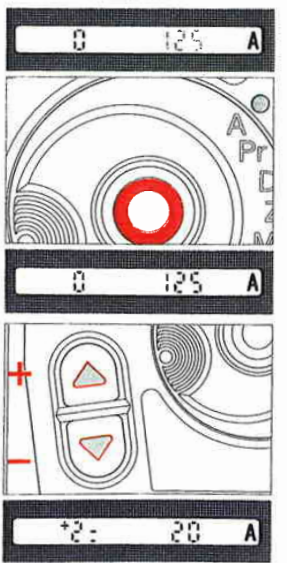

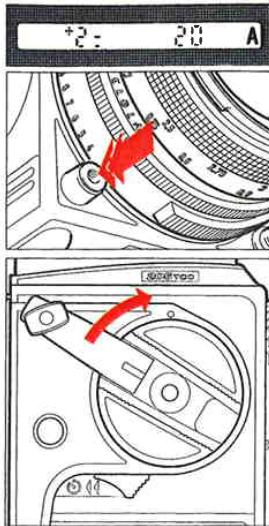

42 Operating Modes, Automatic Mode

### How to use the "Pr" Mode

The Programming Pr Mode can be selected whenever the circumstances require a change of the standard values for selftimer delay, film speed or warning limits for the film contrast range. The changed values

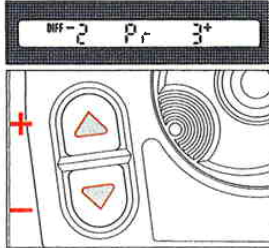
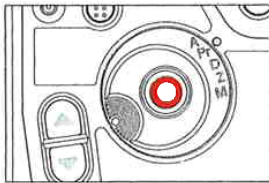

44 Operating Modes, Programming Mode

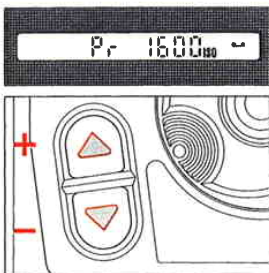

46 Operating Modes, Programming Mode

Any adjustment made with the adjustment buttons remains stored after exposure release until next time the AE-lock button is depressed.

- Depress the exposure button fully to make an exposure according to the stored (and corrected) values. The exposure data remain on the display and the metering system is deactivated until the camera is rewound.

**NOTE:** If the light value have been locked and stored with the AE-lock and the metering spot moved to a different subject area at the moment of exposure, the display will show the correct shutter speed for that particular area after the exposure.

- Rewind the camera to cock the shutter, advance the film for the next frame and reset the metering system to continuous metering with the previous adjustments maintained.

are effective as soon as they are inserted. By repeatedly pressing the AE-lock button you can shift through the Pr-functions in the sequence Pr1->Pr2->Pr3->Pr1-> etc.

### Setting the Contrast Range Warning Limits (Pr1 function)

- Set the Mode Selector Dial in the Pr position.
- Depress the AE-lock button to start the camera and then repeatedly if required to select the Pr1 function.
- Press the adjustment buttons to change the warning limits. Pressing the upper button increases the "+" value and pressing the lower button increases the "-" value. After either value has reached 9 it resets to zero.
- Reset the Mode Selector Dial to the desired exposure mode or press the AE-lock button to switch to next Pr-function.

- Depress the AE-lock button to start the camera and then repeatedly if required to select the Pr3 function.
- Press the adjustment buttons to change the film speed value. The upper button increases and the lower decreases the value in steps of 1/3 EV.
- Reset the Mode Selector Dial to the desired exposure mode or press the AE-lock button to switch to next Pr-function.

**NOTE:** A film speed value manually inserted in the Pr3 function is stored until changed again by the same procedure (or until the battery is removed). If a TCC-magazine is attached the film speed set on the magazine dial overrides the stored value. When the TCC-magazine is detached the stored value is automatically recalled. Thus it is easy to shift between TCC-magazines and a non-TCC-magazine with films of different speeds (e.g. Polaroid films).

### Pr Programming Mode

The Pr mode is not an exposure mode but a setting to program certain values different from the standard settings, which are built into the camera. The standard settings are always set when you activate the system after the battery has been removed or if no other values are stored from previous operations. Any change made in the Pr mode is effective until changed again or until the battery is removed.

The Pr mode is not intended for photographing. If you make an exposure with the camera in Pr mode, the camera automatically shifts to A mode and then immediately back to Pr mode after the exposure.

#### Functions:

**Pr1.** To set the warning for the film dynamic's limits in Differential Mode (page 47) from 0 to +9 and -9 EV resp. The standard setting is -9 EV.

**Pr2.** To set the selftimer delay in the range from 2 seconds to 60 seconds. The available values are: 2, 4, 6, 8, 10, 12, 14, 16, 20, 30, 40, 50, 60 seconds. The standard setting is 10 seconds.

**Pr3.** To set the film speed when you are using non-TCC film magazines. Speed values can be set from 12/12° ISO to 6400/39° ISO in 1/3 EV step (1° ISO) increments. The standard setting is 100/21° ISO.

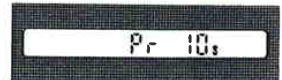
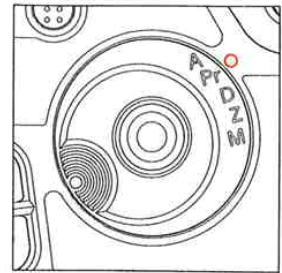

Operating Modes, Programming Mode 43

### Setting the Selftimer Delay (Pr2 function)

- Set the Mode Selector Dial in the Pr position.
- Depress the AE-lock button to start the camera and then repeatedly if required to select the Pr2 function.
- Press the adjustment buttons to change the selftimer delay. The upper button increases the delay and the lower button decreases it with the predetermined steps (Pr2, page 44).
- Reset the Mode Selector Dial to the desired exposure mode or press the AE-lock button to switch to next Pr-function.

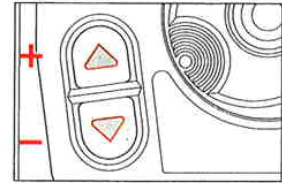

### Setting the Film Speed (Pr3 function)

Setting the film speed in Pr mode is possible only when a non-TCC magazine is used. This is indicated on the display by the symbol "Pr" before the film speed value. With a TCC-magazine the film speed is set on the magazine dial (page 36), the Pr3 function is inactive and the display shows the magazine dial setting only.

- Set the Mode Selector Dial in the Pr position.

(cont'd)

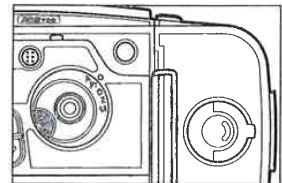

Operating Modes, Programming Mode 45

### D Differential Mode

**Functions:** Automatic exposure with aperture priority, pre-selected film speed and calculated shutter speed.

#### Features:

Continuous metering of the light value. Locking and storing of the light value in a selected moment. Continuous indication of the difference between the stored and the presently metered light value. Adjustment of the stored light value  $\pm 5$  EV-steps in 1/4 EV-step increments.

### How to Use the "D" Mode

The Differential D Mode is very convenient when you want to find out the contrast range of a subject. By locking the exposure values on one subject area and then moving the metering spot about the subject, the display continuously shows the contrast difference between the initial area and the present location of the spot.

#### Suggested procedure:

- Pre-set the film speed. With a TCC-magazine set the film speed dial (page 36). With a standard magazine use the Pr mode to insert and store the film speed (page 45).
- Pre-set the desired aperture.

(cont'd)

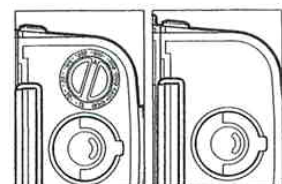
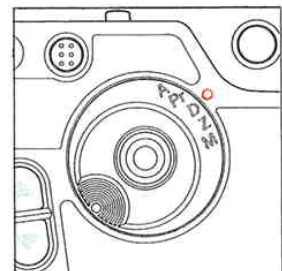

Operating Modes, Differential Mode 47



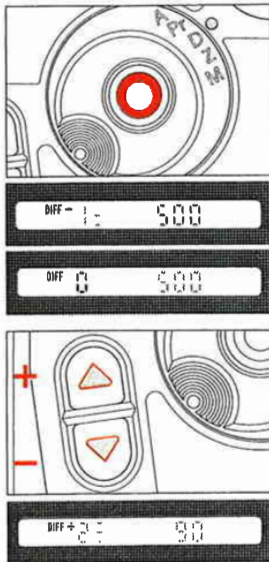

48 Operating Modes, Differential Mode

- Set the Mode Selector Dial at **D** and aim the camera to place the metering spot in a selected subject area.
- Depress the AE-lock button to start the metering system. The viewfinder display shows the symbol "DIFF", the figure "0" and the shutter speed (calculated from the pre-set aperture, the ISO setting and the metered light level) continuously changing the speed as the metering spot is moved to brighter or darker subject areas.
- Release the AE-lock button to lock the exposure value and the shutter speed on a selected "reference" subject area considered to have the desired "normal" brightness. As the metering spot is moved to other subject areas the display continuously shows the brightness difference in + or - EV between the reference area and the present location of the spot with an accuracy of 1/4 EV-step.
- Use the adjustment buttons to adjust the exposure up or down to the desired level with 1/4 EV increments. You can depress the exposure release button to the pressure point to display the pre-set aperture and change it if required. The shutter speed then adjusts automatically to the new aperture setting, but the exposure remains unchanged.
- Depress the exposure release button fully to make an exposure.
- Rewind the camera to cock the shutter and advance the film to the next frame with the previous exposure values and adjustments maintained.

**NOTE:** The metering system can also be started by depressing the exposure release button. It then recalls the latest stored exposure value including any adjustment.

The settings can be erased and the system unlocked only by depressing the AE-lock button or by removing the battery.

## Z Zone Mode

In this section you will only get the instructions on how to operate the 205TCC in the Zone Mode. You will find more comprehensive instructions and hints about applying the Zone Mode in the booklet "The Hasselblad Zone System" which is also supplied together with the 205TCC.

[In the following the word "zone" always applies to zones in the final print or slide.]

### Functions:

Automatic exposure with aperture priority, pre-selected film speed and calculated shutter speed.

### Features:

Continuous metering of the light value.  
 Locking and storing of the light value at a selected moment.  
 Continuous zone indication for the different parts of the subject.  
 Automatic compensation of the exposure and the zone display indication when planned film development corrections are made.  
 Adjustment of the stored light value between zone 0 and zone 10 with 1/4 zone-step increments.

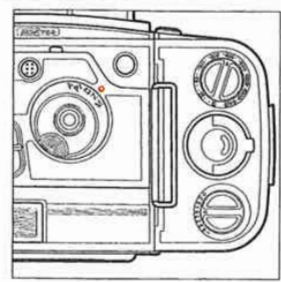

Operating Modes, Zone Mode 49

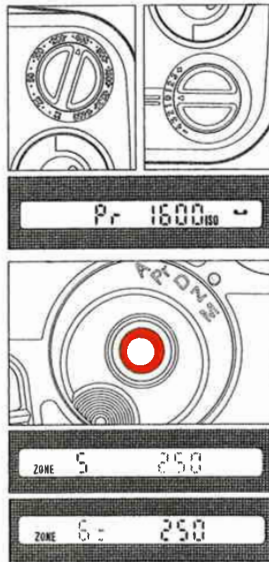

50 Operating Modes, Zone Mode

### How to Use the "Z" Mode

The Zone Z Mode is in many aspects similar to the D mode but has a different way of displaying the contrast differences. With a TCC-magazine it also provides the means to correct for contrast compensation in the film development. This feature is not available with a standard non-TCC magazine.

### Suggested procedure:

- Pre-set the film speed and, if applicable, the contrast correction factor with the respective dials on the TCC-magazine (page 37). With a standard non-TCC magazine use the Pr mode to store the film speed only (page 45).
- Pre-set the desired aperture.
- Set the Mode Selector Dial at Z and aim the camera to locate the metering spot in a selected subject area.
- Start the metering system by depressing the AE-lock button. The viewfinder display shows the symbol "ZONE", the figure "5" and the correct shutter speed, calculated from the pre-set film speed and aperture and the metered light level, continuously changing the shutter speed as the metering spot is moved to brighter or darker subject areas. The figure "5" indicates that the system is placing the presently metered subject area on zone 5.
- Release the AE-lock button when the metering spot is located in a subject area to be placed on zone 5. As the metering spot is moved to other parts of the subject

the display continuously shows on which zone the presently metered area will fall with an accuracy of 1/4 zone-step.

- Use the adjustment buttons to adjust the stored zone 5 location of the initially metered subject area up or down to the desired zone. The shutter speed display changes accordingly but shows half steps only.
- Depress the exposure release button to the pressure point to display the pre-set aperture and change it if required. The shutter speed adjusts automatically to the new aperture setting, but the exposure remains unchanged.
- Depress the exposure release button fully to make an exposure.
- Rewind the camera to cock the shutter and advance the film for the next frame. The exposure values and adjustments remain unchanged until next time you depress the AE-lock button or the adjustment buttons or remove the battery.

**NOTE:** The metering system can also be started by depressing the exposure release button. It then recalls the latest stored exposure value including any adjustment. The settings can be erased and the system unlocked only by depressing the AE-lock button or by removing the battery.

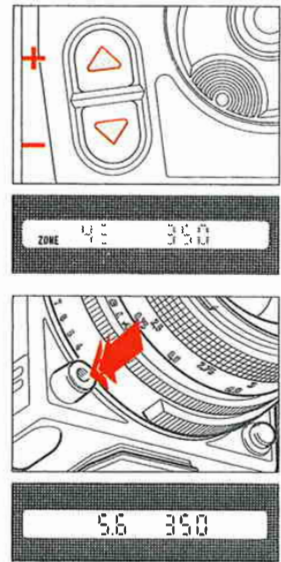

Operating Modes, Zone Mode 51

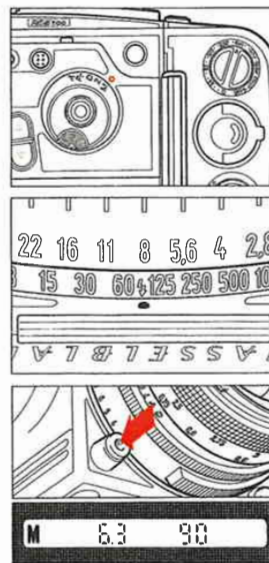

52 Operating Modes, Manual Mode

## M Manual Mode

**Functions:**  
 Manual pre-setting of aperture as well as shutter speed.

**Features:**  
 Completely manually controlled exposure.  
 Continuous metering of the light value.  
 Continuous indication of the difference in EV between the pre-set exposure and the exposure calculated by the camera's CPU.

### How to Use the "M" Mode

The M Mode is completely manual. The metering system is working, but it does not change the shutter speed (the aperture is always pre-set manually). The display indicates the "normal" exposure for the metered area, but the exact exposure will be according to the settings you have made.

### Suggested procedure:

- Pre-set the film speed with the film speed dial on the TCC-magazine or using the Pr mode with a non-TCC magazine. (This point may be omitted but is required for a correct indication on the viewfinder display).
- Set the aperture and the shutter speed manually.
- Set the Mode Selector Dial at M.
- Depress the exposure release button to the pressure point. The metering system starts and the viewfinder display shows the symbol "M" for Manual Mode and the pre-set aperture and shutter speed.

- Release the exposure button. Instead of the aperture value the display starts showing the difference in EV-steps between the set exposure and the "normal" exposure for the present area with an accuracy of 1/4 EV-step, continuously changing the indication as the metering spot is moved about on the subject.
- The adjustment buttons are inoperative in the "M" mode. To change the exposure values, e.g. to adjust the exposure to 0 difference for a certain subject area, change the aperture or the shutter setting (or both) until the difference indication on the display reads within  $0 \pm 1/2$ .
- Depress the exposure release button for an exposure with the set values, independent of the meter readings.
- Rewind the camera to cock the shutter and advance the film for the next frame. All settings remain until you change them manually.

**NOTE:** The metering system could be started by depressing the AE-lock button as well. In that case the display starts by showing the difference as per p.4 above.

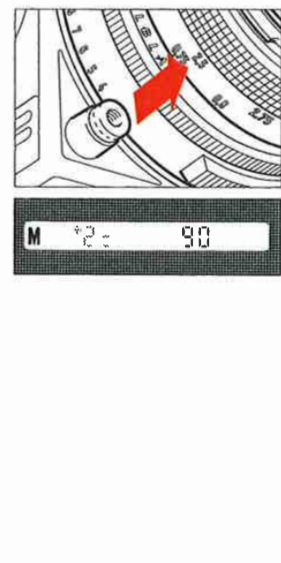

Operating Modes, Manual Mode 51

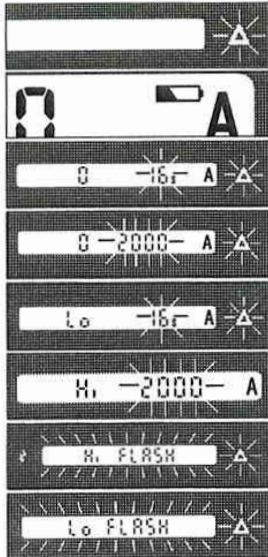

54 Warning Functions, Permanent Warnings

### Warning Functions

Whenever the camera settings could result in an exposure error the red warning triangle flashes.

### Permanent Warnings

The permanent warning functions are built into the system and cannot be changed or disabled.

### Battery Capacity Warning

When the battery voltage drops below a certain point, the battery symbol is displayed whenever the system is working.

### Shutter Speed Warning

When the calculated shutter speed is slower than 1/6 s or faster than 1/2000 s the shutter speed indication and the red warning triangle start flashing.

### Light Meter Range Warning

When the light value falls below or above the range of the light meter the indication "Lo" or "Hi" resp. appears in the left hand part of the display. If no other light value is stored the warning triangle flashes.

### Flash Photography Warnings

In dedicated flash photography the indication "Hi FLASH" or "Lo FLASH" is displayed together with the flashing warning triangle and display backlighting if the flash was too bright or if it was insufficient. This warning is on for 2 seconds after the exposure.

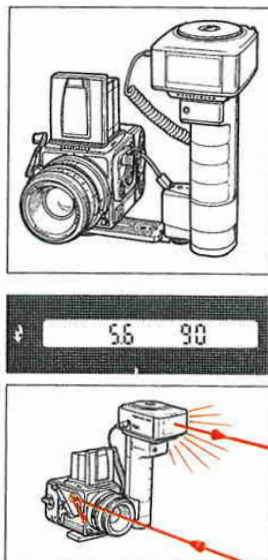

56 Flash Photography, Dedicated Flash

### Flash Photography

#### Dedicated Flash Unit

The automatic flash function in your 205TCC may be looked upon as a sixth mode of operation. When a dedicated flash unit, such as the Hasselblad ProfFlash 4504, or another unit complying with the European SCA-standards is connected to the dedicated flash socket (page 14) – directly or through a suitable adapter – and switched on, your 205TCC automatically shifts to "Flash Mode" when the flash unit is fully charged and ready to flash. The shift occurs regardless of the Mode Selector Dial setting and is indicated in the viewfinder by illumination of the green flash symbol (page 18). Your 205TCC controls the flash duration by TTL/OTF metering (TTL=Through The Lens; OTF=Off The Film), i.e. metering the light reflected off the film and terminating the flash when the exposure is correct.

There is of course also the possibility to connect the flash unit to the PC socket, but then you no longer have the advantage of letting the camera system control the flash and the exposure.

**NOTE:** The spot-metering system is not working when the camera has shifted to the flash mode, indicated by the illuminated green flash symbol in the viewfinder.

Dedicated flash used as fill-in flash, see APPENDIX C, page 93

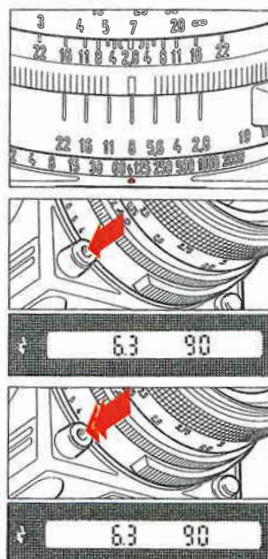

58 Flash Photography, Dedicated Flash

3. Select and pre-set the aperture for the desired depth-of-field. Pre-set the shutter speed at 1/90 s or faster.

**NOTE:** Shutter speeds set slower than 1/90 s are operative and may in result in a mixed-light exposure when the flash and the camera are used in TTL mode.

4. Depress the exposure release button to the pressure point to start the camera. The display indicates the aperture setting and the shutter speed; 1/90 s if the shutter speed is set at 1/90 s or faster or the set speed if it is slower. With the Mode Selector Dial set at A or M the corresponding symbol is also shown but other symbols are not.

5. Depress the exposure release button fully to make the exposure and trigger the flash. The control circuits in the camera cut the flash when the exposure is correct. If the flash was powerful enough to produce a correct exposure but did not use up all the power the flash symbol stays on and the display continues to show aperture and shutter speed. Did it use up most of the power the flash symbol turns off while the flash unit is recharging and lights up again when it is

### Zone Warning

When the metered subject area falls outside the zone range, the ZONE symbol and the zone value figure 0 or 10 flashes.

### Optional Warnings

The optional warning functions can be set, changed or disabled by you.

### Film Dynamic Range Warnings

When the difference between the light value for the metered subject part and the light value stored in the system exceeds the limits you have chosen for the contrast range of the film you are using (page 43, p.1) the difference indication and the DIFF symbol on the display is flashing.

### Optional Shutter Speed Warning

When the shutter speed calculated by the system is slower than the shutter speed set on the shutter speed ring (page 22) the shutter speed indication on the display and the red warning triangle start flashing. This warning can be used e.g. to indicate that the calculated shutter speed is too slow for hand-held photography or to indicate shutter speeds of 1/90 s or slower (page 68). The warning can be shut off for all shutter speeds (up to 1/6 s) by setting the shutter speed ring at 1 s.

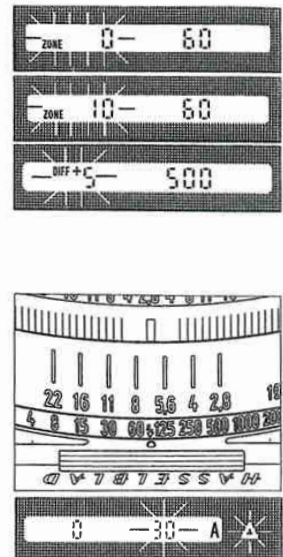

Warning Functions, Optional Warnings 55

### How to Use the Dedicated Flash

#### A. Flash set at TTL Mode

For the operation of the flash unit see the flash unit instruction Manual.

#### Functions:

Fully automatic exposure control through TTL/OTF metering.

Exposure with pre-set aperture and shutter speeds slower than 1/90 s.

Automatic shutter speed shift to 1/90 s when the pre-set shutter speed is faster.

Viewfinder indication when the flash unit is charged and ready to flash.

Viewfinder warning at over- and under-exposure.

#### Suggested procedure:

1. Attach and connect the flash according to the Flash Manual. With the Hasselblad ProfFlash 4504 connect the Hasselblad TTL-cable between the dedicated flash socket in the camera body (page 29) and the TTL socket in the flash unit. The PC connector is inoperative but can be "parked" in the PC-socket.

2. Set the flash unit at TTL or corresponding mode and switch it on. When the flash unit is charged and ready to flash, the green flash symbol (page 18) lights up in the viewfinder.

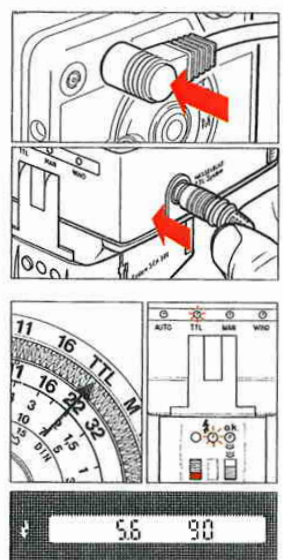

Flash Photography, Dedicated Flash 57

fully recharged. In the meantime the camera shifts to the mode set on the Mode Selector Dial and the display indications change accordingly.

#### WARNINGS (page 54):

The sign "HI FLASH" appears on the display when the flash was too bright, e.g. if the flash-to-subject distance is short, the camera aperture large, the film fast or any combination of these. The remedies are to move the flash away from the subject (use a lens with longer focal length), reduce the aperture, change to a slower film.

The sign "Lo FLASH" appears when the flash was insufficient to give a correct exposure, e.g. if the flash-to-subject distance is too long, the aperture is too small, the film too slow. The remedies are shorter flash-to-subject distance, larger aperture or faster film. In both cases the suggested remedies could be combined in any desired way. These warnings appear for two seconds after the flash exposure.

6. Rewind the camera to cock the shutter and advance the film to the next frame.

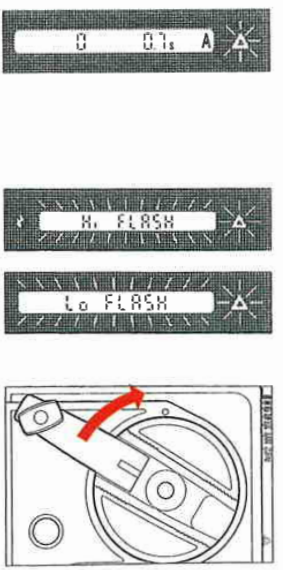

Flash Photography, Dedicated Flash 59

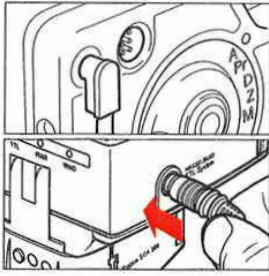

### B. Flash set at Automatic Mode

The flash unit should be set for its own built-in automatic control (see the flash unit instructions)

#### Functions:

Automatic exposure control through the built-in system in the flash unit.  
Exposure with pre-set aperture and shutter speed.  
Automatic shutter speed shift to 1/90 s when the pre-set shutter speed is faster. Viewfinder indication when the flash unit is charged and ready to flash.  
Viewfinder warning at over- and under-exposure.

#### Suggested procedure:

1. Attach and connect the flash according to the Flash Manual. With the Hasselblad Profflash 4504 connect the TTL-cable between the dedicated flash socket in the camera body (page 29) and the TTL socket in the flash unit. The PC connector is inoperative but can be "parked" in the PC-socket.
2. Set the flash unit to Automatic or corresponding mode and switch it on. When the flash unit is charged and ready to flash, the green flash symbol (page 18) lights up in the viewfinder and the shutter speed is automatically changed to 1/90 s if it was set at a faster speed. Shutter speed slower than 1/90 s do not change.

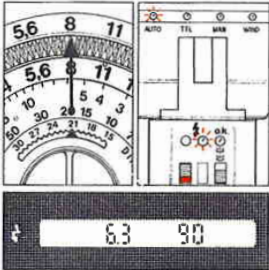

60 Flash Photography, Dedicated Flash

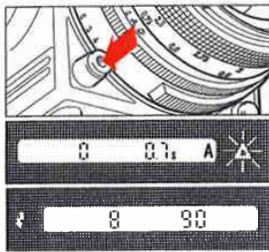

5. Depress the exposure release button fully to make the exposure and trigger the flash. The control circuits in the flash unit cut the flash when the exposure is correct. If the flash was powerful enough to produce a correct exposure but did not use up all the power the flash symbol stays on and the display continues to show aperture and shutter speed. Did it use up most of the power the flash symbol turns off while the flash unit is recharging and lights up again when it is fully recharged. In the meantime the camera shifts to the mode set on the Mode Selector Dial and the display indications change accordingly.



#### WARNINGS (page 54):

The sign "Hi FLASH" appears on the display when the flash was **too bright**, e.g. if the flash-to-subject distance is short, the camera aperture large, the film fast or any combination of these. The remedies are to move the flash away from the subject (use a lens with longer focal length), reduce the aperture, change to a slower film.  
The sign "Lo FLASH" appears when the flash was **insufficient** to give a correct

62 Flash Photography, Dedicated Flash

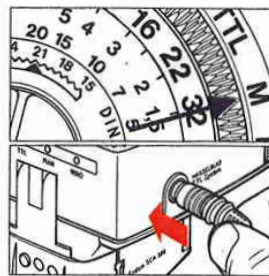

#### Suggested procedure:

1. Attach and connect the flash according to the Flash Manual. With the Hasselblad Profflash 4504 connect the TTL-cable between the dedicated flash socket on the camera body (page 29) and the TTL socket on the flash unit. The PC connector is inoperative but can be "parked" in the PC-socket.
2. Set the flash unit to Manual or corresponding mode and switch it on. When the flash unit is charged and ready to flash, the green flash symbol (page 18) lights up in the viewfinder and the shutter speed is automatically changed to 1/90 s if it was set at a faster speed. Shutter speed slower than 1/90 s do not change.

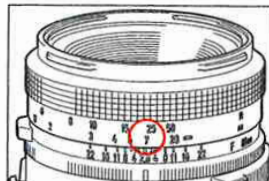
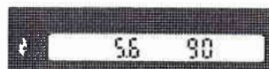

3. Estimate the flash-to-subject distance or measure it by focusing the lens and reading the distance from the focusing scale.

64 Flash Photography, Dedicated Flash

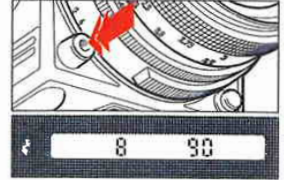
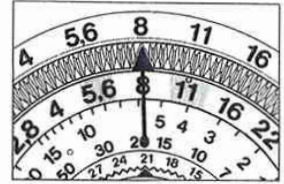
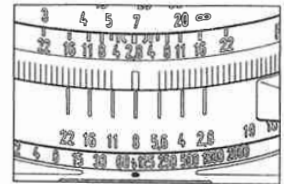

3. Select and pre-set the lens aperture for the desired depth-of-field and set the flash dial at the corresponding aperture value  
or  
set the flash-to-subject distance on the flash dial, read the corresponding aperture value on that dial and pre-set the camera aperture at the same value.

4. Depress the exposure release button to the pressure point to start the camera. The display indicates the aperture setting and the shutter speed; 1/90 s if the shutter speed is set at a faster speed or the set speed if it is slower than 1/90 s. If the Mode Selector Dial set at A or M these symbols are also shown but other symbols are not.

Flash Photography, Dedicated Flash 61

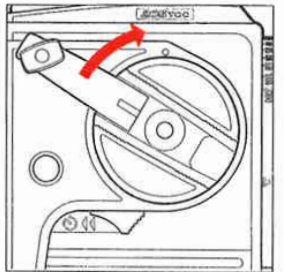

exposure, e.g. if the flash-to-subject distance is too long, the aperture is too small, the film too slow. The remedies are shorter flash-to-subject distance, larger aperture, faster film.  
In both cases the suggested remedies could be combined in any desired way. These warnings appear for two seconds after the flash exposure.

6. Rewind the camera to cock the shutter and advance the film to the next frame.

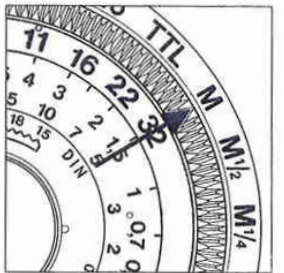

### C. Flash set at Manual Mode

The flash unit should be set for manual control (see the flash unit instructions).

#### Functions:

Exposure with pre-set aperture and shutter speed.  
Automatic shutter speed shift to 1/90 s when the pre-set shutter speed is faster. Viewfinder indication when the flash unit is charged and ready to flash.  
Viewfinder warning at over- and under-exposure.

Flash Photography, Dedicated Flash 63

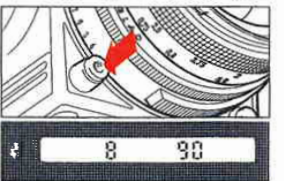
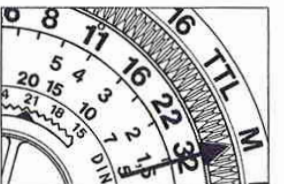

4. Determine the aperture setting using the aperture calculator of the flash unit or using the Guide Number (see the flash unit manual).

5. Depress the exposure release button to the pressure point to start the camera. The display indicates the aperture setting and the shutter speed; 1/90 s if the shutter speed is set at a faster speed or the set speed if it is slower than 1/90 s. If the Mode Selector Dial set at A or M these symbols are also shown but other symbols are not.



6. Depress the exposure release button fully to release the exposure and trigger the flash. In Manual mode the flash normally uses full power. The flash symbol turns off while the flash unit is recharging and lights up again when it is fully recharged. In the meantime the camera shifts to the mode set on the Mode Selector Dial and the display indications change accordingly.

Flash Photography, Dedicated Flash 65

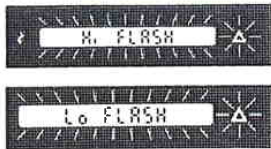

**WARNINGS** (page 54):

The sign "**Hi FLASH**" appears on the display when the flash was **too bright**, e.g. if the flash-to-subject distance is shorter than estimated or the subject brighter than normal. The remedy is to reduce the aperture.  
The sign "**Lo FLASH**" appears when the flash was **insufficient** to give a correct exposure, e.g. if the flash-to-subject distance is longer than estimated or the subject darker than normal. The remedy is to use a larger aperture.

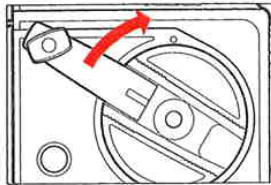

6. Rewind the camera to cock the shutter and advance the film to the next frame.

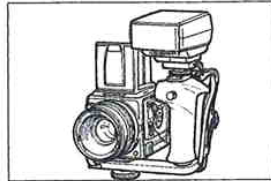

66 Flash Photography, Dedicated Flash

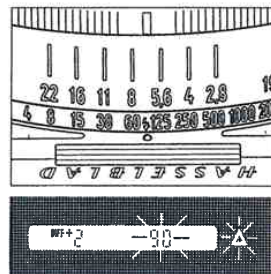

**Suggestion:**

Use the "Shutter Speed Warning" function to verify the shutter speed in **A**, **D** and **Z** modes:

Set the shutter speed ring at 1/90 s (the flash symbol). The red warning triangle and the shutter speed display will start flashing whenever the calculated shutter speed is slower than 1/90 s and the flash will fire properly.

**How to use a Non-dedicated Flash Unit**

**Suggested procedure:**

1. Connect the flash to the PC-socket on the camera body and switch it on.
2. Pre-set the desired aperture.
3. Set the shutter speed at 1/90 s (the flash symbol).
4. Use the camera as described in any desired operating mode, observing the shutter speed warning signal in the modes **A**, **D** and **Z**.

68 Flash Photography, Non-dedicated Flash

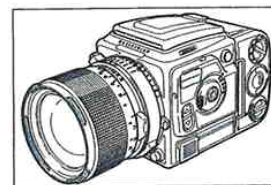

**How to use the 205TCC with an F-lens**

Like all Hasselblad lenses the F-lenses are normally opened up to the largest aperture in viewing position but can be stopped down manually to the pre-set aperture. Since no information on the pre-set aperture is transferred to the metering system in the camera body the shutter speed calculated by the system relates to the actual lens aperture. To get a correctly calculated shutter speed you have to stop down the lens to the pre-set aperture before you make the exposure. With the extra-ordinary brightness of the Acute-Matte focusing screen there are usually no difficulties to focus with a stopped-down lens.

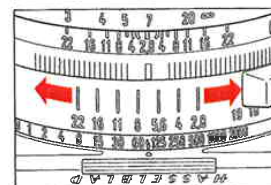

**Suggested procedure:**

1. Pre-set the film speed as previously described.
2. Pre-set the desired aperture value.
3. Set the Mode Selector Dial at the desired mode of operation.
4. Stop down the lens by pushing the preview knob down until it locks the pre-view.
5. Follow the instructions for the selected mode of operation.

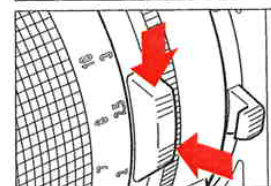

70 Other Hasselblad Lenses, F-lenses

The non-dedicated flash unit should be connected to the PC-socket next to the SCA socket on the left hand side of the camera body by a conventional synchronization cord usually supplied with the flash unit.  
The metering system and the viewfinder display in the camera will work normally in all operating modes as if no flash was connected, i.e. the flash symbol in the viewfinder will not light up when the flash is ready.

**NOTE:** The fastest shutter speed for full flash synchronization is 1/90 s corresponding to the flash symbol on the shutter speed ring. At faster speeds the PC-terminal is disconnected and the flash will not fire. Use this setting and the camera's **M** mode to ensure that the flash will fire.

Since the metering system automatically calculates and sets the correct shutter speed in the modes **A**, **D** and **Z** you must monitor the viewfinder display closely to check that the shutter speed is 1/90 s or slower before making the exposure. Change the pre-set aperture or use the adjustment buttons to change the shutter speed if necessary.

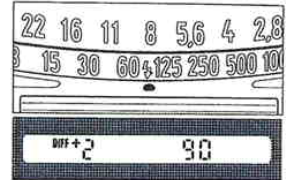
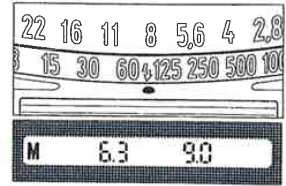
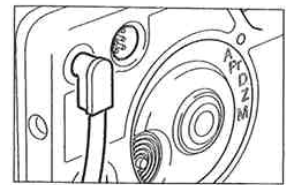

Flash Photography, Non-dedicated Flash 67

**205TCC with other Hasselblad Lenses**

You can use the Hasselblad F-, CF- and C-lenses (lenses without the blue double-line) on your 205TCC without fear of damaging camera or lens. Since these lenses do not have the electronics required by the TCC system, you will not have the full benefit of the TCC advantages and automation. In this section you find information on the F-lenses and how to use them on your 205TCC. How to use the CF- and C-lenses is described in Appendix A, page 83.



**F-Lenses**

The F-lenses are optically, mechanically and operationally identical with the corresponding F/TCC lenses but are not equipped with their internal electronics and external identifications. The instructions for the F/TCC lenses are generally applicable also to the F-lenses (page 31).

**NOTE:** With an F-lens on the camera the aperture value does not appear in the viewfinder display when the exposure or pre-release button is depressed. Instead the display shows two dashes (--).

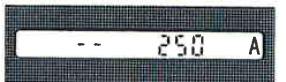
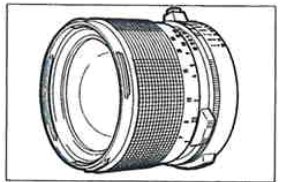

Other Hasselblad Lenses 69

**Flash photography with F-lenses**

The overall similarity between the F/TCC- and F-lenses makes the flash photography procedures almost identical. The only difference is that the aperture value does not appear on the viewfinder display.

**Dedicated Flash Unit**

The TTL/OTF flash control system makes no difference between the F/TCC- and F-lenses as it always operates when the lens is stopped down during the exposure.

**How to use the Dedicated Flash**

The procedures are identical to those described for the F/TCC-lenses in all flash and camera modes of operation (pages 56-63).

**Non-dedicated Flash Unit**

The information and procedure described for the use of a non-dedicated flash unit together with a F/TCC-lens (page 66) is in all parts applicable with an F-lens.

**Accessories**

All accessories originally designed for the 205TCC are marked with the blue twin lines. The mark is always located on that side which is to the left when the accessory is attached to the camera to make it easily identified.

Other accessories are so called "general accessories". These accessories do not have the blue twin lines but can still be used on the 205TCC without restrictions.

A third group of accessories can be used but will cause certain limitations to the TCC functions.

Finally there is a fourth group of accessories that cannot in any way be used on the 205TCC.

**Accessory Mounts**

The quick coupling plate on the bottom of the camera body (pages 25 and 72) fits to the handy and reliable Hasselblad tripod quick coupling and to the flash gun bracket. On the front of the lenses are external and internal bayonet mounts for filters, close-up lenses and lens shades. The viewfinder mount on top of the camera body accepts

Accessories 71

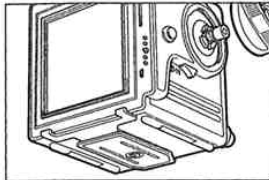

various focusing screens and viewfinders. Underneath the winding crank is a bayonet mount for the Hasselblad Winder.

**Major TCC Accessories**

A selection of the most important TCC accessories is described below. For a complete review of the Hasselblad system refer to the Hasselblad Product Catalog.

**Winder**

The TCC Winder replaces the winding crank and motorizes the 205TCC for a maximum frame rate of 1,3 fps.

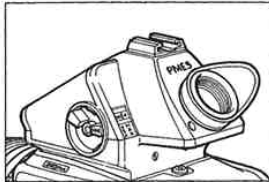

**Viewfinders**

Besides the focusing hood which is delivered with the camera body you have a choice of a magnifying hood and prism viewfinders with and without exposure meters.

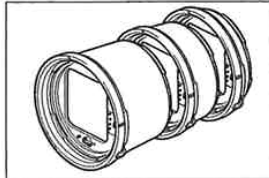

**Extension Tubes**

For close-up and macro photography the TCC extension tubes have all connections, both mechanical and electronic, between camera body and lens.

**External Battery Cassette**

The external battery cassette connector replaces the original battery cassette in the battery compartment. It provides additional power and the extension cord allows you to keep the batteries warm in your pocket when you are using the 205TCC in cold conditions.

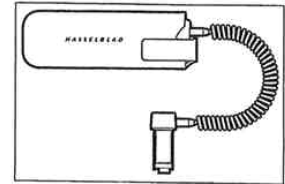

**General Accessories**

The range of general Hasselblad accessories that can be used on the 205TCC without affecting the TCC functions includes different focusing screens, lens shades and filter adapters. There is also the Hasselblad Winder and the Hasselblad Profash 4504 dedicated flash unit. Other dedicated flash units can be connected through flash adapters, such as the Hasselblad SCA 390 and SCA 590.

cannot be used on your 205TCC, such as the other viewfinders, the grips and accessories designed to be attached to the accessory rail on the other Hasselblad reflex models.

**Other Accessories**

These accessories can be used but will result in certain limitations to the TCC system. The F and CF lenses belong to this group as do the common film magazines, the common extension tubes and bellows etc. Also some of the discontinued accessories such as the C lenses belong here. Finally there is a group of accessories which

**The Hasselblad System Chart**

Overleaf you will find the accessory chart that indicates the different groups of accessories in the Hasselblad System. Refer to the Hasselblad Product Catalog for complete information on the entire Hasselblad System.

**Hasselblad System Chart**

**TCC and Accessories**  
Most TCC accessories fit on the other Hasselblad SLR models

**General Accessories**  
Can be used on the 205TCC without changing the TCC operation

**Other Accessories**  
Cause limitations to the TCC operation when used on the 205TCC

**Troubleshooting**

Your Hasselblad 205TCC is built for long and trouble-free service, especially when you follow the advices on maintenance and care (page 94). Should you encounter any operational difficulties the troubleshooting chart below may help you to resolve them.

PROBLEM	POSSIBLE CAUSE	REMEDY
The camera can not be activated in any way.	The battery is removed or completely exhausted. The battery is reversed.	Install or replace the battery. Insert the battery according to the labelling on the battery cassette.
The camera cannot be activated by depressing the AE lock.	The camera was not rewound after the last exposure.	Wind the camera with one full turn of the winding crank.
The exposure release button cannot be depressed.	The AE lock has been depressed for more than 16 seconds. The magazine slide is in the magazine. The roll of film is finished (frame counter at end).	Activate the camera by depressing the exposure release button. Rewind the camera with one full turn of the winding crank. Remove the magazine slide completely. Insert a new film or change to a fully loaded magazine (or w/o film remove and re-insert film holder).
The viewfinder image is dark but the display is bright.	The lens front cover is on.	Remove the lens front cover.

PROBLEM	POSSIBLE CAUSE	REMEDY
The viewfinder image is dark but the display is bright.	The camera is pre-released. The camera has a C lens or a CF lens in C setting attached and was not rewound after the last exposure.	Complete the camera release or depress the double exposure button and wind the camera with one full turn of the winding crank. Rewind the camera with one full turn of the winding crank.
The lens cannot be attached.	The lens is released. The camera body is pre-released or released.	Cock the lens. Release and/or rewind the camera with one full turn of the winding crank.
The lens cannot be detached.	The camera is pre-released or released.	Release and/or rewind the camera with one full turn of the winding crank.
The magazine cannot be detached.	The magazine slide is not completely inserted.	Push the magazine slide in until it positively stops.
The flash symbol does not light up when a dedicated flash unit is connected.	The flash unit is not switched on or is not fully charged and ready to be fired. The connection between flash unit and camera is defective.	Switch on the flash unit and/or wait until it is fully charged. Check the connections according to the flash unit's manual. Replace the TTL sync cord.

### Faulty and Error Indications on the Viewfinder Display (All parts are TCC marked)

PROBLEM	POSSIBLE CAUSE	REMEDY
The display signs appear reversed.	The viewfinder is not properly installed.	Push the viewfinder firmly forwards until it stops.
Aperture indication is "--"	Defective contact between lens and camera body.	Detach the lens. Clean all four contact surfaces on the lens and on the camera body with a lintfree cloth or suede. DO NOT touch the contact surfaces with your fingers!
The magazine symbol appears when a TCC magazine is attached.	Defective contact between magazine and camera body.	Detach the magazine. Clean all four contact surfaces on the magazine and on the camera body with a lintfree cloth or suede. DO NOT touch the contact surfaces with your fingers!
The display indicates "Err 1", "Err 2" or "Err 12 4", possibly together with A or M.	Electronic system error.	Bring the camera to an authorized Hasselblad Service Center. Explain the appearance of the display to the service technician.

**NOTE:** If there is a contact failure between the lens and the camera body you can still use your equipment according to the instruction for the F lens (page 69-70). Contact failure between the magazine and the camera body could be overrun by selecting Pr mode and entering the film speed manually (page 44-45).

78 Troubleshooting

### Technical Specifications and Equipment, 205TCC

<b>Camera Design:</b>	Medium format single lens reflex camera with built-in TTL spotmeter electronically connected to TCC lenses and TCC magazines. Interchangeable lenses, film magazines, viewfinders and focusing screens.
<b>Shutter:</b>	Electronically controlled mechanical focal plane shutter with release solenoid system. Horizontally running textile curtains. Shutter speed range B, 1/6s - 1/2000s. Fully mechanical C setting for built-in leaf shutter lenses. Flash synchronization from B up to 1/90s.
<b>Lens Mount:</b>	Hasselblad bayonet mount for TCC, F, CF and C lenses. Contacts for databus communication with the TCC lenses.
<b>Viewfinder:</b>	Focusing hood with 4x magnifier, interchangeable with magnifying hood and prism viewfinders with and without exposure meter. TCC viewfinders only acceptable. Acute-Matte focusing screen interchangeable with other Hasselblad focusing screens. Illuminated flash and warning symbols.
<b>Operation Display:</b>	LCD display in viewfinder with all relevant exposure and operational data and switch-controlled low light illumination.
<b>Camera Winding &amp; Film Advance:</b>	Manual single turn winding crank. Simultaneous shutter cocking and film advance. The crank is interchangeable with the Hasselblad motor winder for up to 1.3 frames/second.
<b>Exposure Meter:</b>	TTL metering at full aperture with TCC lenses. High sensitivity silicon photocell. Spotmeter area approximately 1% of the image area, angleof view from approximately 1°-7° depending on lens focal length. Metering range EV -1 to EV 20 at ISO 100/21° and f/2.8. Active time 16 s after release of activating button.

more>

Technical Specifications 79

<b>Exposure Functions:</b>	Aperture priority automatic exposure, automatic flash control and full manual control. Exposure compensation $\pm 5$ EV with 1/4 EV increments. AE-lock.
<b>Operating Modes:</b>	Automatic Mode, Differential Mode, Zone Mode, Manual Mode and Programming Mode.
<b>Film Speed Range:</b>	ISO 12/12° to ISO 6400/39°, selected with film speed dial on TCC magazines or entered in programming mode.
<b>Flash Control:</b>	Center weighted TTL/OTF flash exposure meter. Full dedicated flash control with automatic shutter speed reset to 1/90 s at faster speed settings. Inhibited flash triggering in at shutter speed settings faster than 1/90 s with non-dedicated flash units.
<b>Selftimer:</b>	Default delay 10 s. Delay programmable in 12 steps from 2 s to 60 s.
<b>Battery:</b>	6V, type PX28, UCAR 537, 4G-13 or equivalent lithium type.
<b>Tripod Mount:</b>	Quick coupling plate and 1/4" socket thread.
<b>External Dimensions:</b>	Camera body only — see page 81. With focusing hood, lens Planar F 2,8/80 TCC and magazine A 12 TCC 178L x 118W x 108H mm (7 x 4 5/8 x 4 1/4 in.)
<b>Weight:</b>	1615 g with focusing hood, lens Planar F 2,8/80 TCC, A12TCC magazine and battery. Body alone: 745 g.

The camera body (chrome finish P/N 10405, black finish P/N 10413), comes with focusing hood, focusing screen, winding crank, shoulder strap, front and rear protective covers.

For comprehensive information on accessories please refer to the Hasselblad Product Catalog.

80 Technical Specifications

### Camera Body Dimensions

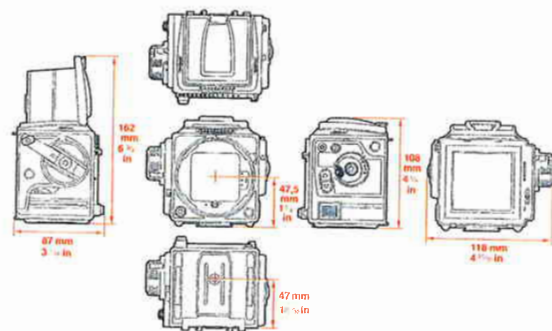

Hasselblad reserve the right to change the specifications without prior notice.

Hasselblad 205TCC is covered by several Swedish and foreign patents.

Dimensions 81

### Camera Care, Service and Guarantee

#### Camera Care

Your Hasselblad camera is designed to withstand the rigours of professional use in most environments. In order to avoid the possibility of damage, however, the camera should be protected from the following.

**Extremes of temperature.** High temperatures can have an adverse effect on both the film and the camera. Do not keep your camera in places where it may get hot, such as in direct sunlight or above a radiator. In tropical environments fungus growth can be prevented by keeping your equipment in an area with circulating air. Frequent rapid and severe temperature changes may cause problems such as corrosion of electrical contacts, and should be avoided. When used in extremely cold temperatures, cameras and especially lenses should be protected as much as possible.

**Dust and grit.** Prevent dirt of any kind from getting into your camera. When taking photographs in coastal areas for example, the camera should be protected from sand and salt water spray.

You can blow away dust on the lens glass, magnifier of focusing screen, or wipe it off gently with a soft cloth. Smears on the lens glass should be removed with a high quality lens cleaning solution on a soft, clean tissue. Be careful not to scratch the lens or touch any of the glass surfaces with your fingers. The surface of the mirror is coated and should be blown clean but not be

wiped. Lens cleaning solvents or other chemicals should not be used on the focusing screen.

**Impact.** Your camera can be damaged by severe physical shocks. You should take care not to leave it where it can fall or be knocked to the ground, or roll about.

#### Service

Faultless camera performance is essential to the professional photographer. Therefore it is advisable to check that your camera is functioning correctly before an important assignment. You should also return your camera to a Hasselblad Service Center for periodical checking and preventive maintenance. If your camera is used constantly and intensively, exposing hundreds of rolls of film per week, check-ups every six months are recommended. Hasselblad Service Centers have the expert staff and specialized equipment necessary to ensure that your camera remains in perfect working order.

#### Guarantee

Provided that you bought your camera from an authorized Hasselblad outlet, it is covered by an international guarantee for one year. The guarantee document and a registration card are supplied with the camera. Keep the guarantee document carefully, but fill in the registration card and return it to your Hasselblad distributor.

### APPENDIX A

#### Hasselblad 205TCC with CF- and C-lenses

The CF- and the older C-lenses differ from the F/TCC- and F-lenses through their built-in leaf shutter with shutter speeds from 1 to 1/500s and B. Both types have full flash synchronization on all shutter speeds. The CF-lenses also have an additional shutter setting F to let the lens be used together with the focal plane shutter and the instant return mirror.

**NOTE:** When using the 205TCC with a CF- or C-lens in cold conditions do not use the lens shutter at 1/500 s.

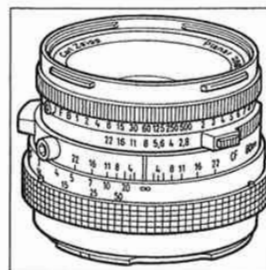

#### CF-lenses

With a CF-lens on your 205TCC you can choose to use the focal plane shutter with all its advantages and full automation or to disengage the focal plane shutter and benefit from the advantages of lens' built-in leaf shutter with full flash synchronization on all shutter speeds.

#### CF-lens design and functions

The setting rings and scales on the CF-lenses are arranged differently from those on the F-lenses. Counted from the camera body and forwards the rings are:

Focusing ring with focusing distance scale in feet (orange) and meters (white).

Common index line and depth-of-field scale.

Aperture ring with aperture scale and EV index (orange).

Shutter speed ring with shutter speed scale, EV scale (orange) and F lock button (green).

82 Care, Service & Guarantee

APPENDIX A: CF-lenses 83

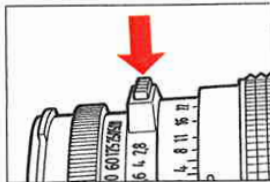

#### EV Interlock Button

Depressing the EV interlock button interlocks the shutter speed and aperture rings to make it possible to change the speed/aperture setting while retaining the EV value.

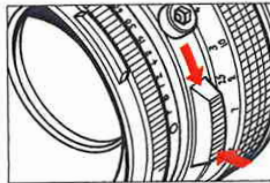

#### Depth-of-field Preview Knob

The Depth-of-field Preview knob location and operation is identical to the FTCC- and F-lenses (page 32).

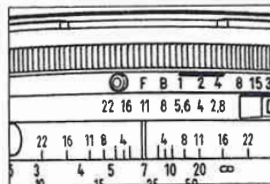

#### F-setting

Depress the small green F-lock button to the left of the green F on the shutter speed ring. Keep it depressed while turning the ring to align the F with the index line. Release the button to lock the ring in the F position. The F setting locks the shutter wide open without interfering with the aperture function. With this setting the lens works exactly as an F-lens (page 69).

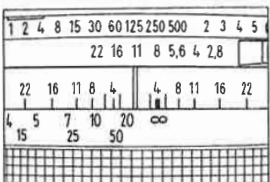

- Pre-set the desired aperture and shutter speed on the lens scales.
- Press the exposure button to make an exposure with the pre-set values.
- Rewind the camera to get the viewfinder image back, advance the film to the next frame and to cock the lens shutter.

**NOTE:** Setting the camera's shutter speed ring at C turns off the entire TCC metering system. The viewfinder display shows only (—) for the aperture and (—c) for the shutter speed when the exposure or pre-release button is depressed. The AE-lock button is inoperative.

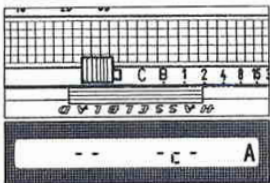

#### Flash photography with CF-lens

The CF-lenses have a built-in X-type flash synchronization at all shutter speeds. Flash connection is the PC socket located on the left hand side of the lens, close to the depth-of-field scale.

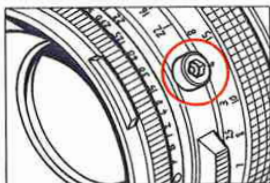

#### How to use the Dedicated Flash

(Camera shutter speed set at C)

##### Suggested procedure:

- Attach the flash to the camera if desired.
- Connect the TTL-cord according to the flash instruction.
- Connect the PC-connector to the PC-socket on the CF-lens, not to the PC-socket in the camera body.
- Set the flash unit in the desired mode of operation and switch it on. The green flash symbol in the viewfinder lights up when the flash is ready to fire.
- Select shutter speed and pre-set aperture on the lens.
- Press and release the exposure button to make an exposure, observing the viewfinder display for warning indications.
- Rewind the camera to get the viewfinder image back, cock the shutter and advance the film to the next frame.

**NOTE:** When used at full power some electronic flash units have a flash duration longer than 1/500 s. To take advantage of the full flash power in such cases and to avoid "Lo FLASH" warning and under-exposure you are recommended to use shutter speeds of 1/125 s or slower.



#### How to use the CF-lens

##### A. Lens in F mode (leaf shutter open)

##### Suggested procedure:

- Turn the shutter speed ring to the F setting.
- Operate the camera as described for the F-lens.

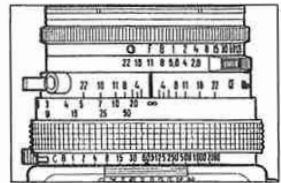

##### B. Lens in C mode (leaf shutter working)

When using the built-in leaf shutter in the CF-lens the focal plane shutter in the camera body must be disengaged. By setting the camera's shutter speed ring in the C position (page 22, 23) the focal plane shutter is turned into an auxiliary shutter, only used to protect the film from inadvertent exposure.

**NOTE:** The leaf shutter remains closed leaving the viewfinder screen dark until the camera is rewound.

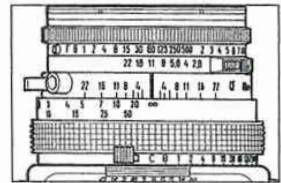

##### Suggested procedure:

- Check that the lens' shutter speed ring is not set at F.
- Keep the lens catch button depressed while turning the camera's shutter speed ring to align the C at the end of the scale with the red index mark.
- Release the lens catch button to lock the shutter speed ring in the C setting.

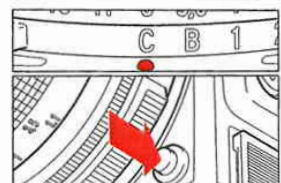

#### Lens in F mode

##### Dedicated and non-dedicated Flash Units

The procedures are identical to the corresponding procedures for the F-lens (page 71).

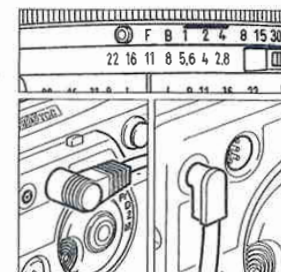

#### Lens in C mode

##### Dedicated Flash Unit

Although the TCC metering system is turned off in C mode the TTL/OTF system is still working to control the dedicated flash unit directly – as with the Hasselblad Prolash 4504 – or through a suitable adapter. However, since the focal plane shutter is not working as a shutter the triggering of the flash must come from the shutter in the CF-lens. The green "ready" flash symbol works and the "Hi FLASH" and "Lo FLASH" warning indications may appear in the viewfinder when the exposure button is released.

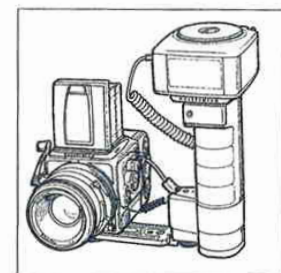

#### Non-dedicated Flash Units

The non-dedicated flash unit should be connected to the PC-socket on the lens only. The exposure is controlled either by the flash itself or by aperture value settings calculated from the guide manual. There will be no indications or warnings in the viewfinder.

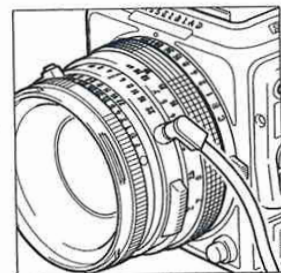

#### How to use the Non-dedicated Flash Unit (Camera shutter speed set at C)

##### Suggested procedure:

- Attach the flash to the camera if desired.
- Connect the synch cord to the PC-socket on the CF-lens, not to the PC-socket in the camera body.
- Set the flash unit at the desired mode and switch it on.
- Set and pre-set aperture and shutter speed (preferably 1/125 s or slower).
- Press the exposure button to make an exposure.
- Rewind the camera to get the viewfinder image back, cock the shutter and advance the film to the next frame.

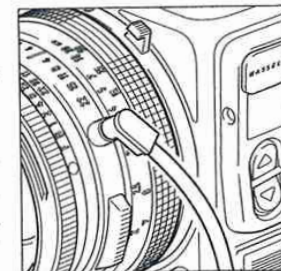

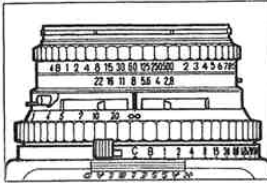

### C-lenses

The older C-lenses (production terminated in 1982) look different but are in most respects identical to the CF-lenses. There are, however, four major differences:

1. There is no F-setting on the shutter.
2. The shutter speed and aperture rings are normally interlocked.
3. There are two different flash synchronization modes.
4. There is a built-in mechanical selftimer.

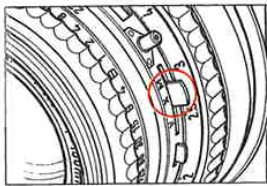

### How to use the C-lens

Avoid using the focal plane shutter together with a C-lens. If it cannot be avoided follow the procedure below:

1. Set the lens shutter at B.
2. Pre-set the desired aperture.
3. Set the camera shutter at the desired shutter speed.
4. Press the exposure button to make an exposure.
5. Rewind the camera to get the viewfinder image back, cock the shutter and advance the film to the next frame.

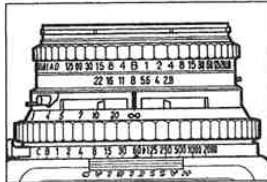

### Lens in C mode

The procedure is identical with the CF-lens procedure (page 85).

90 APPENDIX A: C-lenses

### Flash photography with the C-lens

**Using the camera's focal plane shutter**  
With the lens shutter set at B the lens can be used as an F-lens.

**Dedicated and Non-dedicated Flash Units**  
Follow the corresponding procedures for the F-lens (page 71).

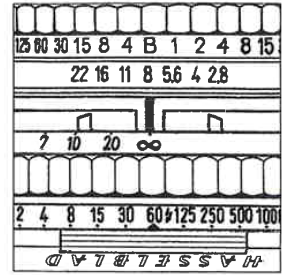

### Using the C-lens leaf shutter

Make sure that the flash mode selector is set at X.

**Dedicated and Non-dedicated Flash Units**  
Follow the corresponding procedures for the CF-lens (page 87).

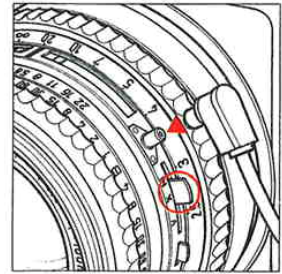

APPENDIX A: C-lenses 91

## APPENDIX B Spotmeter Metering Angle for all Hasselblad Lenses

Values in degrees with lens focused at infinity and without close-up accessories. — indicates that the combination is not applicable.

	Lens type		Lens alone	Lens with PC-Mutar 1,4x	Lens with Mutar 2x
	F	F/TCC			
Distagon CF 30	Distagon F 50	Distagon F 50 TCC	11,4	—	5,7
Distagon CF 40			8,6	6,1	4,3
Distagon CF 50			6,9	4,9	3,4
Distagon CF 60			5,7	4,1	2,9
Planar CF 80			4,3	3,1	2,1
Planar CF 100	Planar F 110	Planar F 110 TCC	3,4	2,5	1,7
UV-Sonnar CF 105			3,3	—	—
Makro-Planar CF 120			3,1	—	1,6
Makro-Planar CF 135*	Sonnar F 150	Sonnar F 150 TCC	2,9	—	1,4
Sonnar CF 150			2,6	—	—
Sonnar CF 180			2,3	—	1,2
Sonnar CF 250	Sonnar F 250	Sonnar F 250 TCC	1,9	—	1
Tele-Tessar CF 350			1,4	—	0,7
Tele-Apotesar CF 500	Tele-Tessar F 350	Tele-Tessar F 350 TCC	1	—	0,5
Variogon CF 140-280	Tele-Apotesar F 500	Tele-Apotesar F 500 TCC	0,7	—	0,3
			2,4-1,2	—	—

\*The Makro-Planar CF 135 mm lens can only be used together with the extension bellows or the variable extension tube for close-up work.

92 APPENDIX B: Spotmeter Angles

## APPENDIX C Hasselblad 205TCC with Dedicated Fill-in Flash

When a dedicated flash is connected to the TTL-socket, the 205TCC automatically shifts to "Flash Mode" with TTL/OTF metering as the flash is charged and ready to flash (page 56). The spotmeter system is then shut off and the TTL/OTF system controls the exposure. If you wish to use the dedicated flash as a fill-in flash in TTL mode you need both metering systems to get a correct exposure. The method below can be used regardless of attached filters or close-up accessories.

1. Shut off the flash to shift to the spotmeter system.
2. Meter the selected subject area with the spotmeter.
3. Change the pre-set aperture until the display shows a shutter speed not faster than 1/90 s.
4. In A, D or Z mode set the shutter speed ring at the displayed speed. In M mode change the pre-set aperture and/or the shutter speed until the display shows 0 deviation.
5. Switch on the flash to return to the "Flash Mode" when the flash indicator lights up.
6. Press the exposure button normally to make an exposure.

**NOTE:** In "Flash Mode" the shutter speed is never faster than 1/90s also when the shutter speed is set at a faster setting. Slower speeds, however, are obtained by setting the ring at the desired slower speed.

### Alternative method

A dedicated or non-dedicated computer flash connected to the PC-socket does not shut off the spotmeter system and gives no indications on the viewfinder display. Use the camera as if no flash is connected but set the ISO setting on the flash higher than the film used if you wish to reduce the flash effect. Observe the "ready"-light on the flash, not in the viewfinder.

APPENDIX C: Fill-in Flash 93